

**TEKTRONIX®**

**7D12  
A/D  
CONVERTER**  
SERVICE

INSTRUCTION MANUAL

Tektronix, Inc.  
P.O. Box 500  
Beaverton, Oregon 97005

Serial Number \_\_\_\_\_

070-1470-00

First Printing JUNE 1974



## **WARRANTY**

**All TEKTRONIX instruments are warranted against defective materials and workmanship for one year. Any questions with respect to the warranty should be taken up with your TEKTRONIX Field Engineer or representative.**

**All requests for repairs and replacement parts should be directed to the TEKTRONIX Field Office or representative in your area. This will assure you the fastest possible service. Please include the instrument Type Number or Part Number and Serial Number with all requests for parts or service.**





**Specifications and price change privileges reserved.**

**Copyright © 1974 by Tektronix, Inc., Beaverton, Oregon. Printed in the United States of America. All rights reserved. Contents of this publication may not be reproduced in any form without permission of Tektronix, Inc.**

**U.S.A. and foreign TEKTRONIX products covered by U.S. and foreign patents and/or patents pending.**

**TEKTRONIX is a registered trademark of Tektronix, Inc.**

# TABLE OF CONTENTS

	Page		Page
TABLE OF CONTENTS	i	<b>SECTION 3 MAINTENANCE</b>	
LIST OF ILLUSTRATIONS	ii	PREVENTIVE MAINTENANCE	3-1
LIST OF TABLES	iii	Introduction	3-1
<b>SECTION 1 OPERATING INFORMATION</b>		Cleaning	3-1
PRELIMINARY INFORMATION	1-1	Visual Inspection	3-1
7D12 Features	1-1	Recalibration	3-1
Display Modes	1-2	TROUBLESHOOTING	3-2
7D12 Installation	1-2	Troubleshooting Aids	3-2
Module Installation	1-2	Troubleshooting Equipment	3-2
<b>SECTION 2 THEORY OF OPERATION</b>		Troubleshooting Procedure	3-2
PRELIMINARY INFORMATION	2-1	CORRECTIVE MAINTENANCE	3-4
BLOCK DIAGRAM	2-1	General	3-4
Block Diagram Description	2-1	Obtaining Replacement Parts	3-4
LOGIC TRIGGERING	2-2	Soldering Techniques	3-4
4-1/2 DIGIT A/D CONVERTER		Component Replacement	3-5
AND LOGIC	2-3	Circuit Board Replacement	3-6
READOUT LOGIC	2-5	Switch Replacement	3-7
THE TEKTRONIX READOUT		<b>SECTION 4 PERFORMANCE CHECK/CALIBRATION</b>	
SYSTEM	2-8	PRELIMINARY INFORMATION	4-1
INVERTER POWER SUPPLY	2-10	Calibration Interval	4-1
DUAL-TRACE VERTICAL		Tektronix Field Service	4-1
AMPLIFIER	2-11	Using This Procedure	4-1
CIRCUIT OPERATION	2-11	Test Equipment Required	4-1
VERTICAL AMPLIFIER 	2-12	PART 1—PERFORMANCE CHECK	4-5
4-1/2 DIGIT A/D CONVERTER 	2-13	Index to Part 1—Performance	
LOGIC 	2-13	Check	4-5
POWER AND CONNECTORS 	2-14	Preliminary Procedure for	
		Performance Check	4-5

# TABLE OF CONTENTS (cont)





	Page	
<b>SECTION 4 PERFORMANCE CHECK/CALIBRATION (cont)</b>		<b>SECTION 5 ELECTRICAL PARTS LIST</b>
VERTICAL DISPLAY	4-6	
VOLTAGE READOUT DISPLAY AND TRIGGERING	4-7	
GATE DISPLAY	4-8	<b>SECTION 6 DIAGRAMS AND CIRCUIT BOARD ILLUSTRATIONS</b>
PART II—CALIBRATION PROCEDURE	4-9	
Index to Calibration Procedure	4-9	
Preliminary Procedure For Calibration	4-9	<b>SECTION 7 MECHANICAL PARTS LIST</b>
FLOATING POWER SUPPLY	4-10	
VERTICAL DISPLAY	4-12	<b>CHANGE INFORMATION</b>
BANDWIDTH	4-14	
ANALOG TO DIGITAL CONVERTER	4-16	

# LIST OF ILLUSTRATIONS

Figure Number	Page	Figure Number	Page	
1-1	Frontispiece.	2-4B	Block diagram of the 4-1/2 Digit A/D Converter (cont.)	2-7
1-2	7D12 Front-panel control and connector functions.	2-5	Block diagram of the Readout Logic section.	2-9
1-3	Display mode switch location and functions.	2-6	Block diagram of the Inverter Power Supply.	2-10
1-4	7D12 and module installation.	2-7	Block diagram of the Dual-Trace Vertical Amplifier section.	2-11
2-1	Block diagram of module and 7D12 A/D Converter.	4-1	7D12 Calibration Fixture installed.	4-5
2-2	Block diagram of the Logic Triggering section.	4-2	Typical Inverter pulse waveform properly neutralized.	4-11
2-3	Timing diagram of the 4-1/2 Digit A/D Converter.	4-3	Typical time-slot pulses with relation to the readout display	4-17
2-4A	Block diagram of the 4-1/2 Digit A/D Converter.	4-4	Typical example of gate pulse neutralization.	4-19



## LIST OF ILLUSTRATIONS (cont.)

Figure Number		Figure Number	
6-1	Semiconductor lead configurations Block Diagram.	6-5	(A3) Triggering switch board component locations.
6-2	(A1) Mainboard component locations.	 3	Logic.
 1	Vertical Amplifier.	6-6	(A2) Floating board component locations.
6-3	A2) Floating board component locations.	 4	Power and Connectors.
 2	4-1/2 Digit A/D Converter.	6-7	(A1) Main circuit board adjustment locations.
6-4	(A1) Mainboard component locations.	6-8	(A2) Floating circuit board adjustment locations.

## MECHANICAL PARTS LIST ILLUSTRATIONS

### Figure Number

1	Exploded view.
2.3	Accessories and Repackaging.
4	Dimensions.

## LIST OF TABLES

Table Number		Page
2-1	7D12 Readout Format	2-8
2-2	U148 Input/Output Table for CH 1 and CH 2 Display Modes	2-12
3-1	Fuse Ratings	3-7
4-1	Test Equipment	4-2
4-2	Vertical Display Amplitude and Lower Numerical Readout	4-6
4-3	Floating Power Supply Limits	4-10
4-4	Vertical Display Amplitude and Lower Numerical Readout	4-13

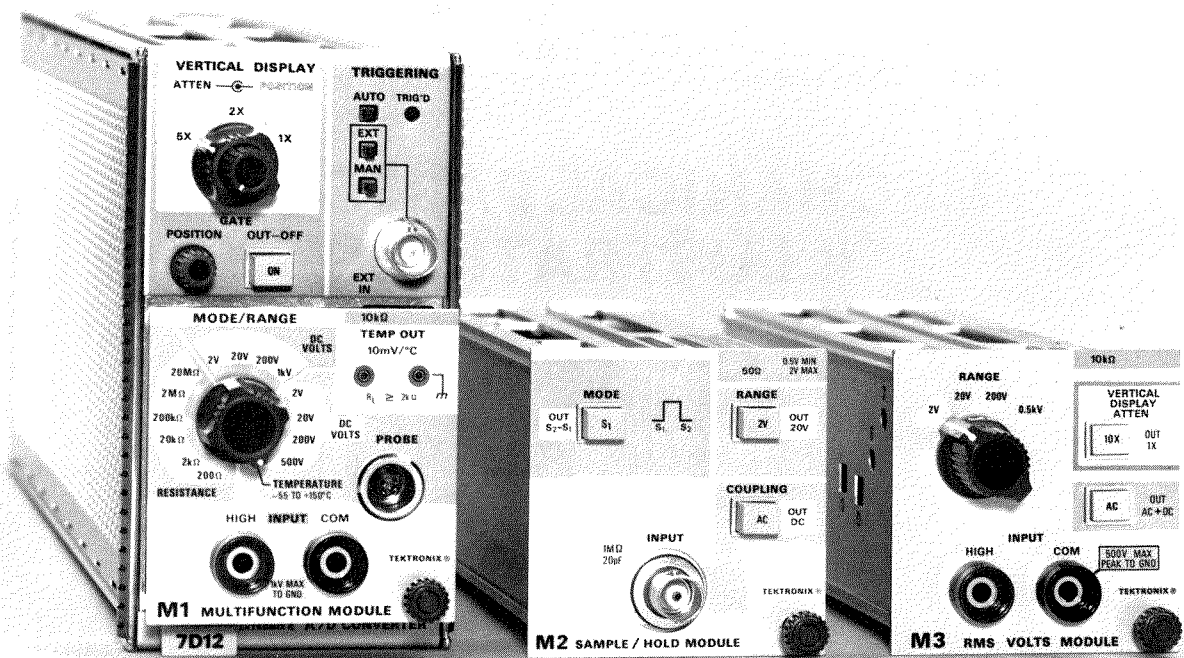

Fig. 1-1. 7D12 A/D Converter with M1 Multi-function Module partially installed, M2 Sample/Hold Module, and M3 RMS Volts Module.

# OPERATING INFORMATION

## PRELIMINARY INFORMATION

### 7D12 FEATURES

The 7D12 is an analog to digital converter for use with any 7000-series oscilloscope mainframe that contains readout. Several plug-in modules are available for use with the 7D12. Depending upon the plug-in module used, the 7D12 can supply up to a 4-1/2 digit display with a full scale reading of 20000 on the mainframe crt. When not used, the most significant digit of the display is suppressed. Automatic polarity and overflow indicators are also

contained in the 7D12. The A/D Converter can be triggered internally by the plug-in module, manually by a front-panel switch, or externally from a trigger source such as the 7D15 Period Timer. The 7D12 also contains a vertical display amplifier that displays the signal applied to the module, and a gate display amplifier that displays a representation of the 7D12 internal gate signal.

Since the 7D12 function is dictated by the module installed, instructions for operating the 7D12 are located in the Operating Instructions for each module (i.e., M1, M2 or M3). A brief description of the 7D12 Front-Panel Controls and Connectors is shown in Fig. 1-2.

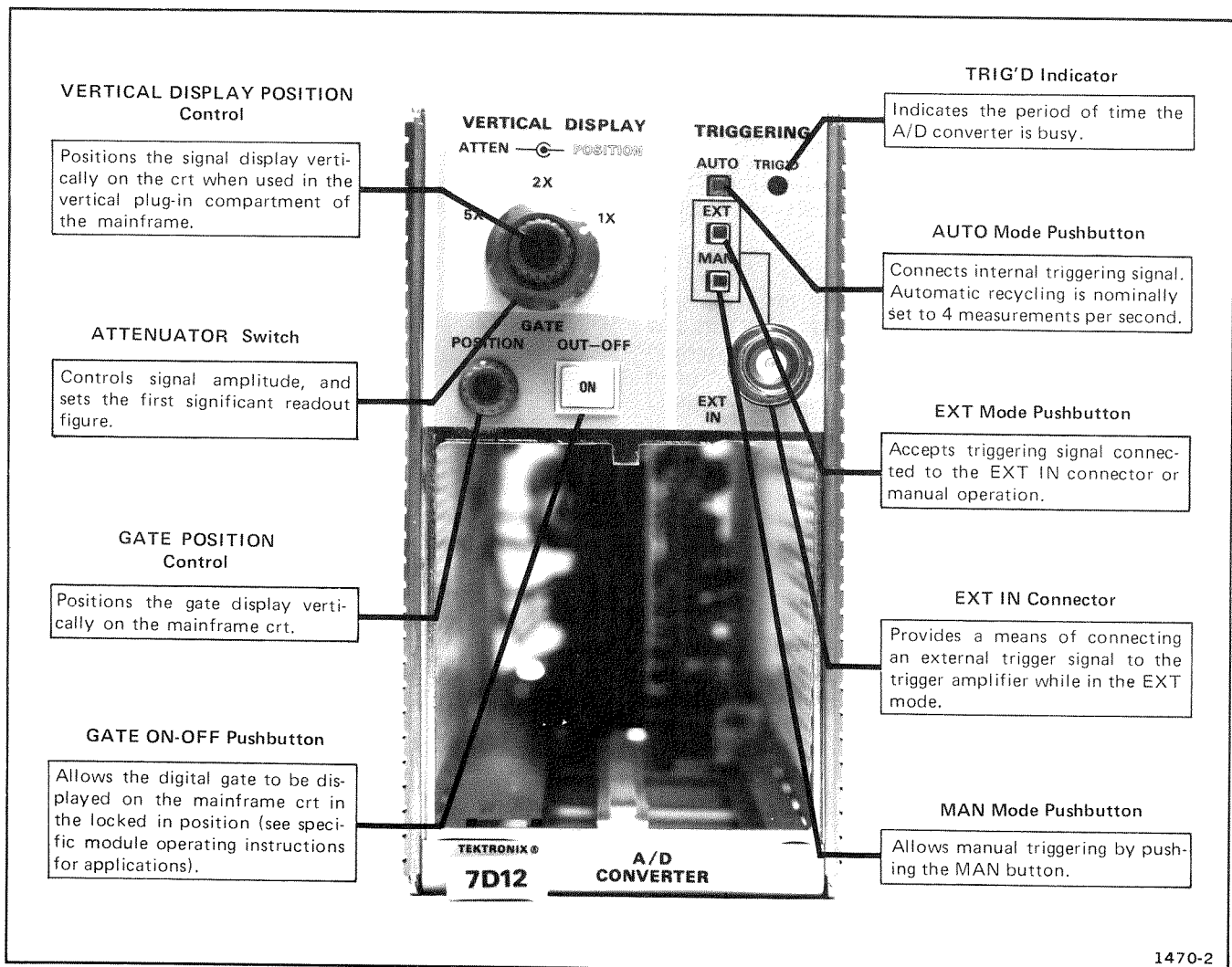

Fig. 1-2. 7D12 Front-panel control and connector functions.

**DISPLAY MODES**

The vertical display and the internal gate display can be operated in either alternate or chop mode, depending upon the internal Display Mode switch setting; see Fig. 1-3.

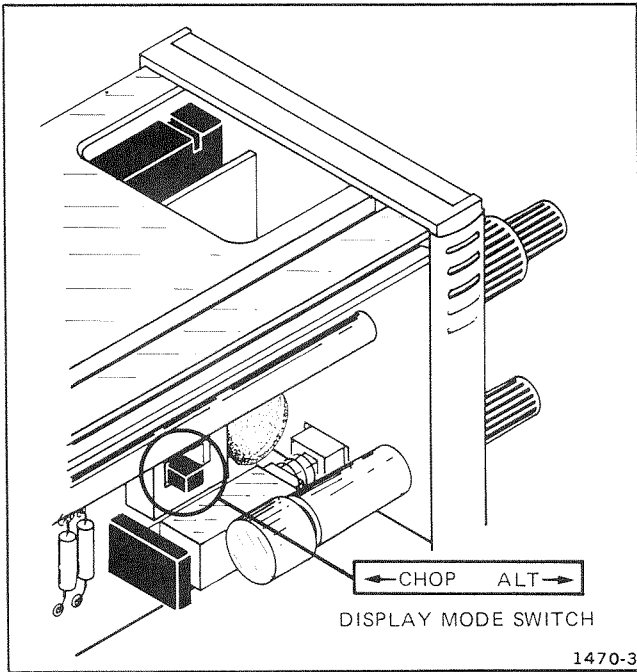

Fig. 1-3. Display mode switch Location and functions.

**Alternate Mode**

The Alt position (toward front panel) of the Display Mode switch produces a display that alternates between the vertical display and the gate display with each sweep on the crt. Although the Alt mode can be used at all sweep rates, the Chop mode provides a more satisfactory display at sweep rates below about 0.2 millisecond per division. At slow sweep rates, alternate mode switching becomes visually perceptible.

**Chop Mode**

The Chop position (toward rear) of the Display Mode switch produces a display that is electronically switched between the input display and the trigger gate display at approximately a 500 kilohertz rate (controlled by main-frame). In general, the Chop mode provides the best display at sweep rates slower than about 0.2 millisecond per division.

**7D12 INSTALLATION**

**CAUTION**

Extreme care should be exercised when handling the 7D12 to prevent touching any part of the circuit boards. This unit contains several high impedance circuits which can develop inter-leakage if contaminated by body salts or acids. Refer to the Maintenance Section of this manual for recommended cleaning methods and solvents.

The 7D12 is calibrated and ready for use with a module as received. It can be installed in any compartment of Tektronix 7000-series oscilloscopes, but is intended principally for use in vertical plug-in compartments. To install, align the upper and lower rails of the 7D12 with the oscilloscope tracks and fully insert it. The front is flush with the front of the oscilloscope when the 7D12 is fully inserted, and the latch at the bottom-left corner of the 7D12 will be in place against the front panel. See Fig. 1-4.

Set the oscilloscope for a vertical mode to correspond with the vertical compartment used when an analog signal is to be displayed. The digital readout will be displayed regardless of the vertical mode selected.

To remove the 7D12, pull on the latch (which is inscribed with the unit identification "7D12") and the 7D12 will unlatch. Continue pulling on the latch to slide the 7D12 out of the oscilloscope.

**MODULE INSTALLATION**

All modules are calibrated and ready for use with the 7D12 as received. To install, align the upper and lower rails of the module with the 7D12 module-compartment tracks and fully insert it. The front is flush with the front of the 7D12 when the module is fully inserted. Lock the module securely in position by rotating the retaining knob clockwise until it is finger-tight. See Fig. 1-4. To remove the module, reverse the above procedure.

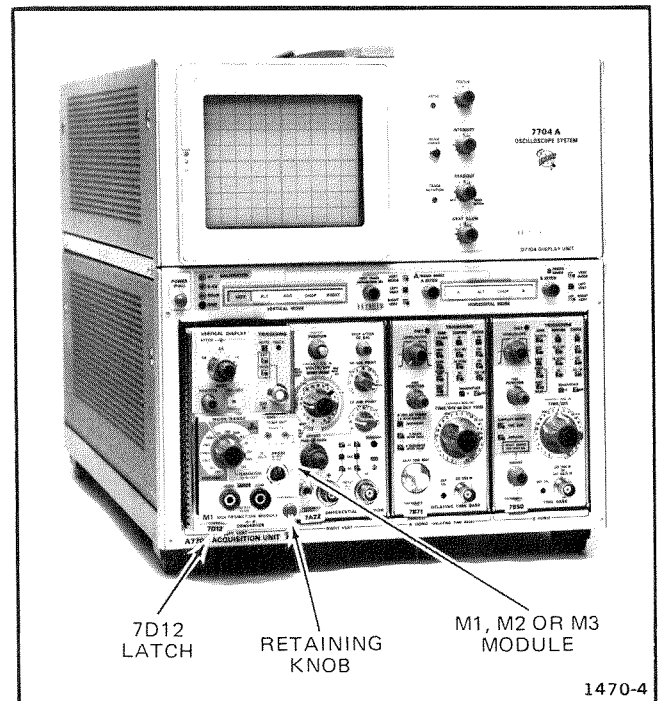

Fig. 1-4. 7D12 and module installation.

# THEORY OF OPERATION

## PRELIMINARY INFORMATION

## BLOCK DIAGRAM

### INTRODUCTION

This section of the manual describes the circuitry used in the 7D12 A/D Converter. The description begins with a discussion of the instrument, using the basic block diagram shown in Fig. 2-1. Next, each major circuit is described in detail, using detailed block diagrams to show the relationship between stages in each major circuit. Detailed schematics of each circuit are located in the Diagrams Section at the back of this manual; refer to these schematics throughout the following circuit description for specific electrical values and relationships.

### BLOCK DIAGRAM DESCRIPTION

The function of each block in the basic block diagram, Fig. 2-1, is readily apparent except for the Inverter Power Supply. This supply permits floating the A/D Converter section, enabling measurements with the inputs elevated as high as 1 kV. Further, not all modules utilize the Display and Gate amplifier circuits shown. Each block represents a major circuit within the instrument. The numbered diamond in each block refers to the circuit diagram, (located at the back of this manual) which covers that specific part of the instrument.

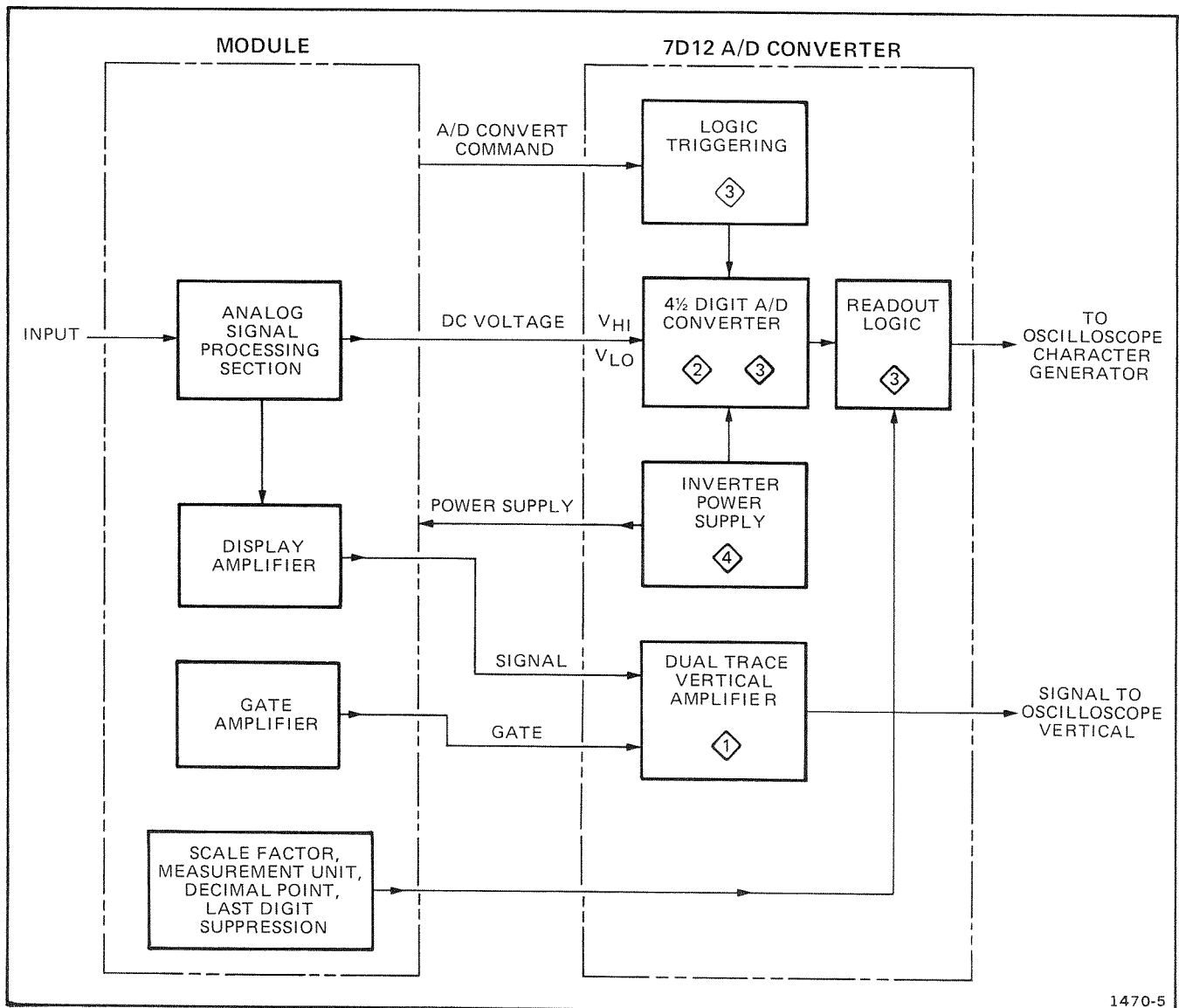

Fig. 2-1. Block diagram of module and 7D12 A/D Converter.

## Theory of Operation—7D12 Service

The 7D12 A/D Converter plug-in unit contains a fast, 4-1/2 digit analog-to-digital converter, Inverter Power Supply, Dual-Trace Vertical Amplifier, Readout Logic and Trigger Logic circuit. The modules process various analog signals, such as peak voltage, rms voltage, resistance, temperature, etc. and produce a dc voltage which the 7D12 converts to digital readout information for the 7000-series oscilloscope. The modules also provide an analog signal for display on the crt.

## LOGIC TRIGGERING

### INTRODUCTION

The block diagram for the Logic Triggering circuitry is shown in Fig. 2-2. The trigger signal is connected internally from the 7D12 A/D Converter to the module. The M1 and M3 modules return the trigger signal directly

to the 7D12 A/D Converter as an A/D Convert Command. The M2 module, however, holds the trigger signal until the M2 sampling process is complete before releasing an A/D Convert Command.

### TRIGGERING SWITCH

#### Auto Mode

Free-Run Oscillator Q610 is connected as the trigger source. The oscillator has a nominal output frequency of 4 hertz.

#### External Mode

The Free-Run Oscillator and +5 volt sources are disconnected. External trigger signals connected to the 7D12 EXT IN connector are used directly as the trigger source.

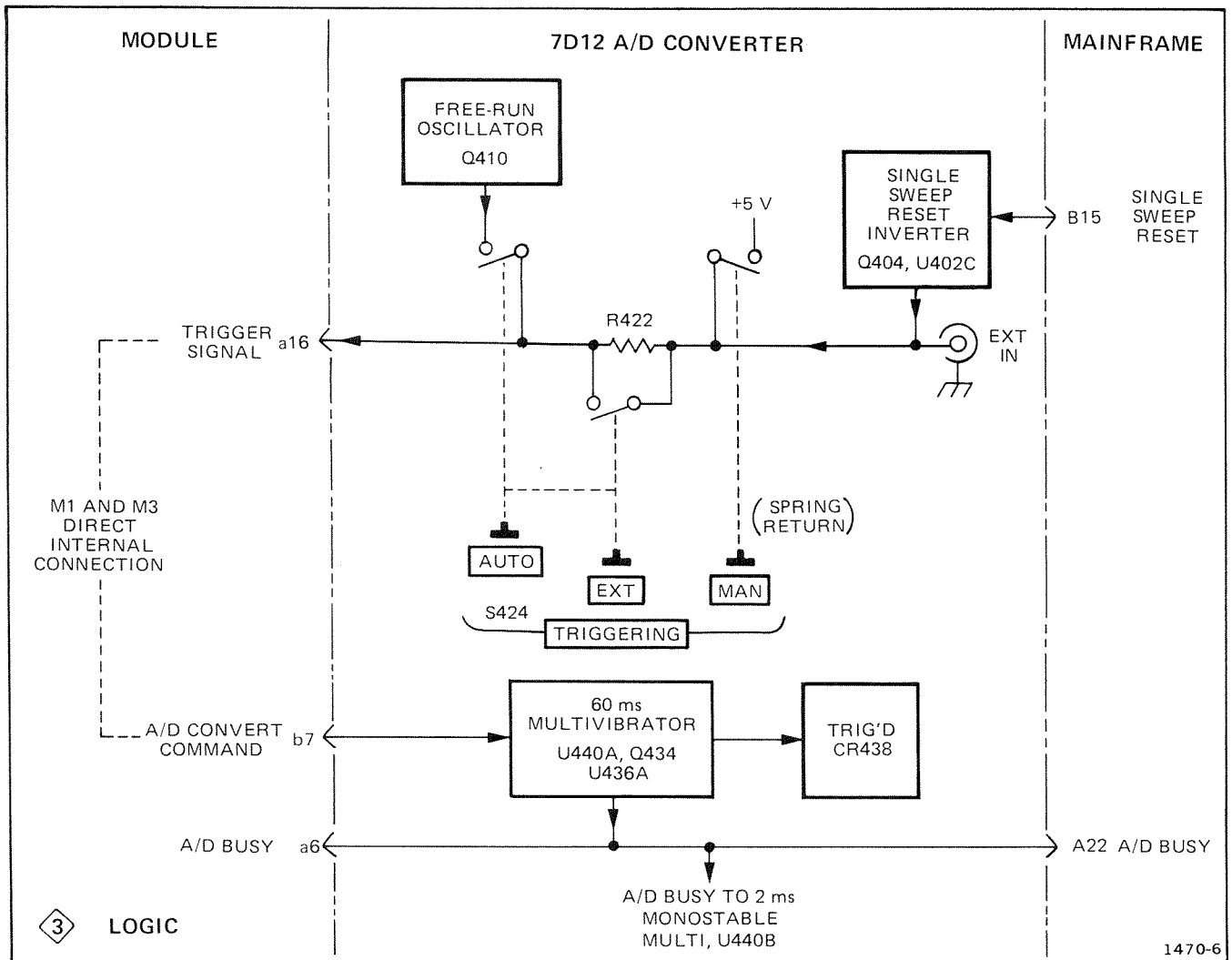

Fig. 2-2. Block diagram of the Logic Triggering section.

### Manual Mode

The Free-Run Oscillator is disconnected and the EXT switch is closed, shunting R422. Manual operation provides a +5 volt pulse as the trigger signal.

### TRIGGER HOLDOFF

The trigger signal becomes the A/D Convert Command either directly or indirectly, depending upon the module used. The A/D Convert Command switches the state of the 60 mS Multivibrator. The multivibrator rejects all additional A/D Convert Command signals during the 60 millisecond period. The TRIG'D indicator, CR438, is energized during the 60 millisecond period to indicate the measurement circuits are busy.

## 4-1/2 DIGIT A/D CONVERTER AND LOGIC

### INTRODUCTION

A block diagram of the 4-1/2 Digit A/D Converter and Logic functions is shown in Fig. 2-4. Refer to the timing diagram in Fig. 2-3 and the block diagram in Fig. 2-4 throughout the following discussion. All of the switches shown in Fig. 2-4 are electronic switches such as MOS-FETs, JFET's and diodes. The circuitry enclosed by the dotted lines is a floating section powered by the Inverter Power Supply. Positive logic is assumed to set and reset all circuit shown in the block diagram.

### BEFORE TIME ZERO

The following conditions exist before a trigger signal (A/D Busy) is received at the 2 mS Monostable MV (Multivibrator) U440B.

1. The analog output of the module is coupled to the 4-1/2 Digit A/D Converter  $V_{hi}$  and  $V_{lo}$  electronic input switches.

2. Sw 1 is open and Sw 2 is closed, disconnecting  $V_{hi}$  and connecting  $V_{lo}$  to the input of the Buffer and  $|G_m|$  Converter stages.

3. Sw 3 is closed, connecting the Auto-Zeroing Circuit to the  $|G_m|$  Converter. The Auto-Zeroing Circuit automatically produces the same voltage level at Input 2 as that of the offset voltage appearing at Input 1, thereby

holding the  $|G_m|$  Converter output at zero volts. Capacitor C302 stores the offset voltage required to hold the  $|G_m|$  Converter output at zero volts during integration.

4. Sw 6 is closed, setting the Integrator output to zero volts.

### AT TIME ZERO ( $t_0$ )

A negative-going trigger pulse (A/D Busy) Sets the 2 ms Monostable MV U440B. The 0 output of the MV holds the Clock Sync ff (flip-flop) Master Reset and the Measurement Period ff, Set on for 2 milliseconds. The 0 output pulse from the Clock Sync ff performs the following functions:

1. Sets the A/D Standby ff changing the electronic switch stages as follows:

- a. Sw 1 closes and Sw 2 opens, disconnecting  $V_{lo}$  and connecting  $V_{hi}$  to the input of the Buffer and  $|G_m|$  Converter stages.

- b. Sw 3 opens, disconnecting the Auto-Zeroing Circuit from the  $|G_m|$  Converter output. The charge on capacitor C302 maintains the offset voltage balance between Input 1 and Input 2; therefore, the  $|G_m|$  Converter output remains referenced at zero volts.

- c. Sw 6 opens, arming the Integrator circuit.

2. Sets the Measurement Period ff.

3. The 1 output from the 2 ms Monostable MV U440B, Resets the 4 Decade Counter-Latches in U500, thereby clearing any stored information from the previous measurement.

The 2 millisecond delay between  $t_0$  and  $t_1$  allows all switching circuits and the  $|G_m|$  Converter to stabilize before starting the measurement.

### AT TIME ONE ( $t_1$ )

The 2 ms Monostable MV, U440B, returns to its original state, thereby releasing the Clock Sync ff Master Reset. The first negative-going pulse from the 1 mHz Clock Generator, U402, Sets the Clock Sync ff. The 0 output from the Clock Sync ff enables AND gate U436C and U492C, allowing the clock signal to pass and begin counting at the Counters. The 0 output from the Clock

Theory of Operation—7D12 Service

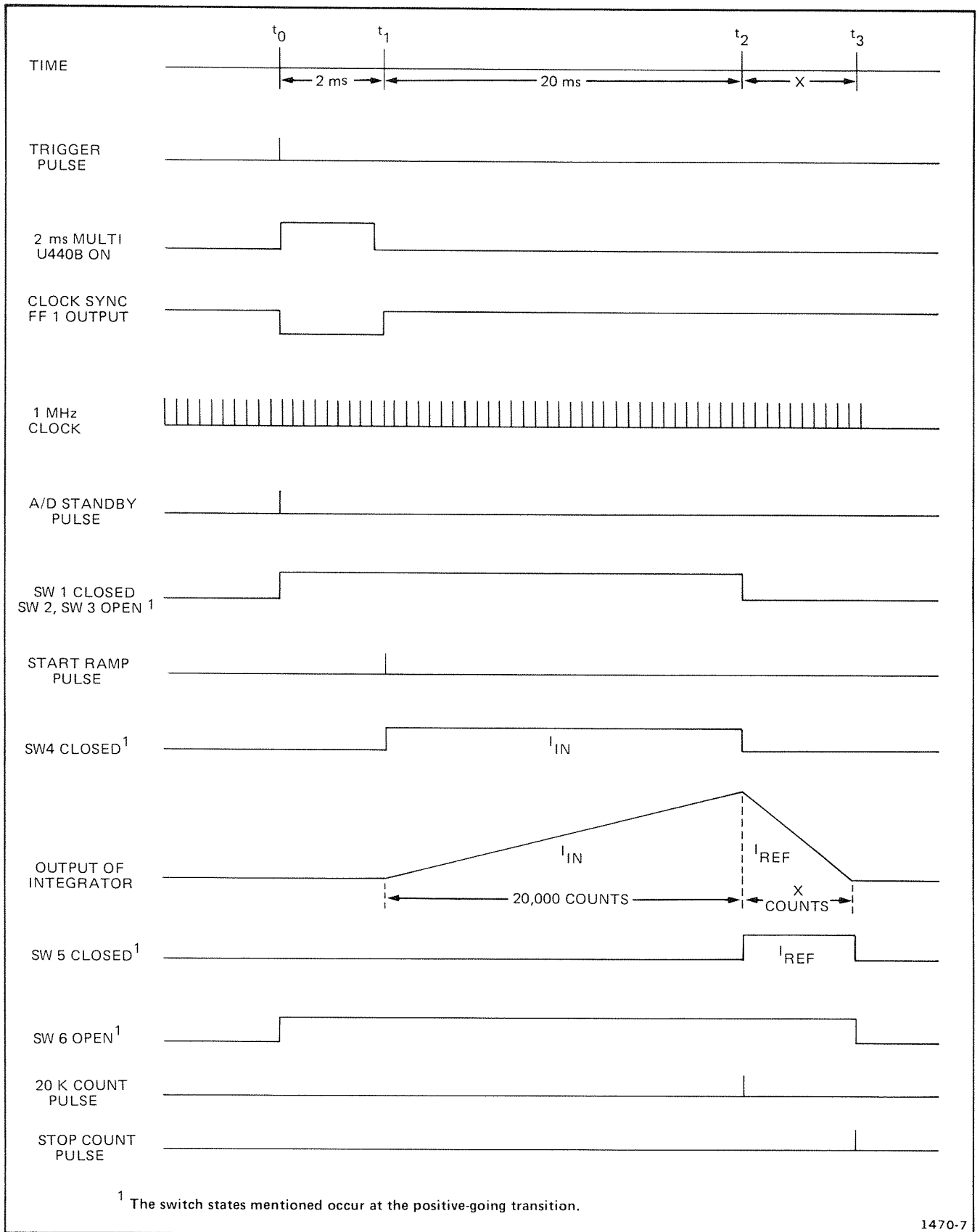

Fig. 2-3. Timing diagram of the 4 1/2 Digit A/D Converter.



Sync ff also enables the Start Ramp ff, closing Sw 4. The rectified input current ( $I_m$ ) from the  $|G_m|$  Converter begins to charge capacitor C379 in the Integrator.

The 0 output from the Clock Sync ff Sets the A/D Converting Pulse Generator ff, U436B and D, thereby allowing the 1 output to go hi at  $t_1$ .

### AT TIME TWO ( $t_2$ )

The 4 decade Counter-Latches and  $\div 4$  ff have counted 20,000 clock pulses. At the 20K count, the  $\div 4$  ff generates a negative-going pulse to the 20K Count Logic circuit. The output of the 20K Count Logic changes the electronic switch states as follows:

1. Resets the Start Ramp ff that switches:
  - a. Sw 4 open, disconnecting the  $|G_m|$  Converter output from the Integrator.
  
2. Sets Stop Count ff that switches:
  - a. Sw 5 is closed, connecting the Reference Current Generator output to the Integrator.
  
3. Resets the A/D Standby ff that switches:
  - a. Sw 1 is open and Sw 2 is closed, disconnecting the input signal to the Buffer and  $|G_m|$  Converter stages.
  
  - b. Sw 3 is closed, connecting the Auto-Zeroing Circuit to the  $|G_m|$  Converter.
  
4. Resets the A/D Converting Pulse Generator ff, U436B and D. The 1 output goes hi at  $t_1$  and lo at  $t_2$ . The A/D Converting Pulse is connected to the module gate circuitry, allowing the measured gating time ( $t_1$ - $t_2$ ) to be observed on the crt display.

The Reference Current Generator output current ( $I_{ref}$ ) begins discharging C379, and the 4 Decade Counters-Latches are cleared to measure C379 discharge time.

### AT TIME THREE ( $t_3$ )

The output of the Integrator (C379) is discharged to zero volts and the Comparator output Resets the Stop Count ff. The 0 output of the Stop Count ff changes the electronic switch states as follows:

1. Sw 5 opens, disconnecting the Reference Current Generator.
  
2. Sets the Integrator Zeroing Logic circuit, closing Sw 6. Sw 6 holds the Integrator output level at zero volts.
  
3. Resets the Measurement Period ff. AND gates U436C and U492C are disabled, preventing the 1 MHz clock pulse from reaching the counters. AND gate U492D is enabled, transferring the stored information in the 4 Decade Counters and  $\div 4$  ff to the Latches. The output of the Latches is connected to the Readout Control Section in the mainframe.

A 60 millisecond monostable multivibrator in the Trigger Logic circuit prevents another trigger from occurring until one measurement cycle has been completed.

## READOUT LOGIC

### INTRODUCTION

The Readout Logic circuit encodes the Indicator Oscilloscope readout system to display the measurement made by the 7D12 and module. The Readout Logic circuit also encodes the readout system to display the appropriate measurement units and polarity symbols, along with positioning the display decimal point and indicating an over-range measurement.

A discussion entitled the Tektronix Readout System following the 7D12 Theory of Operation gives a brief description of the readout system used in Tektronix 7000-series Oscilloscopes.

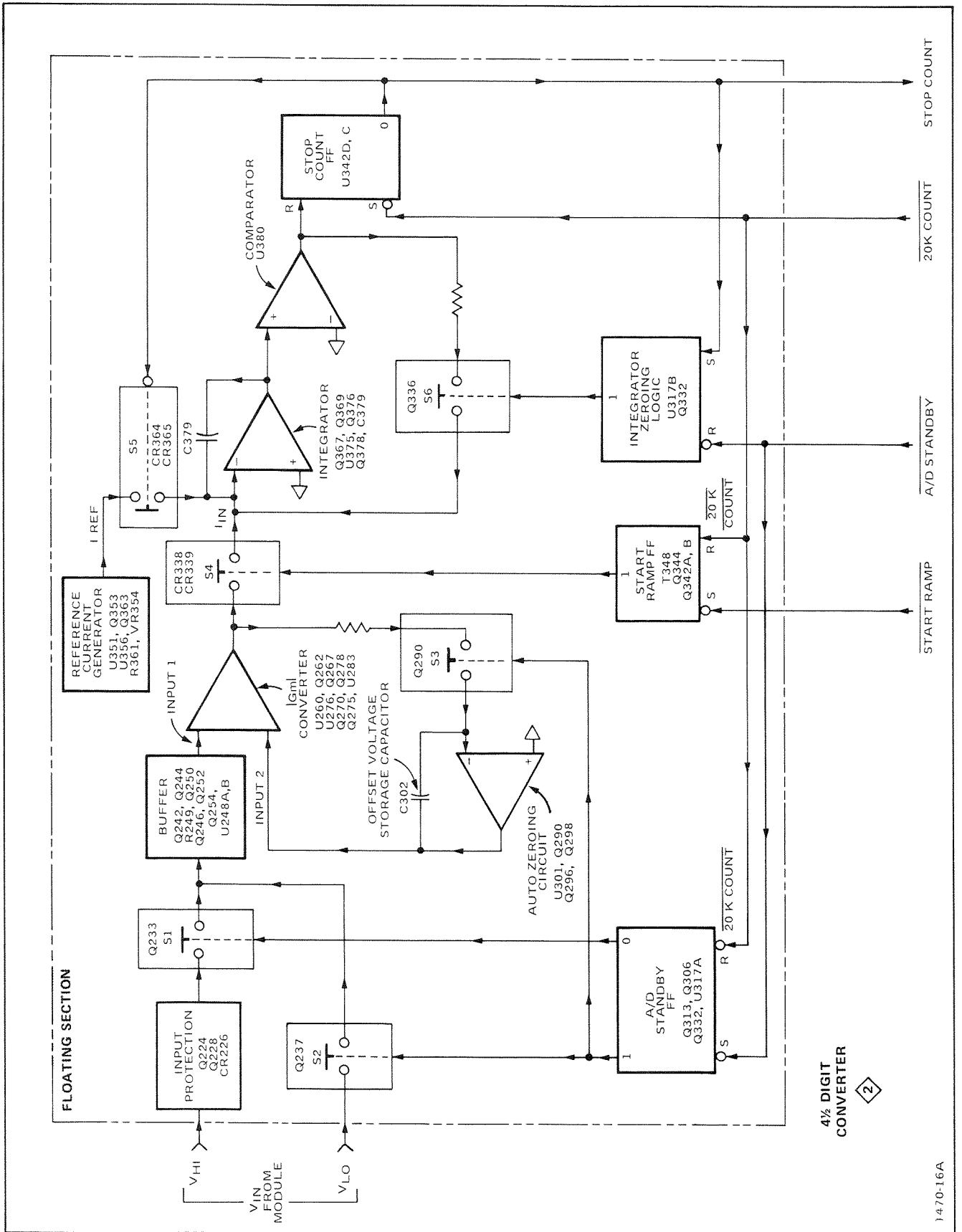

Fig. 2-4A. Block diagram of the 4 1/2 Digit A/D Converter section.

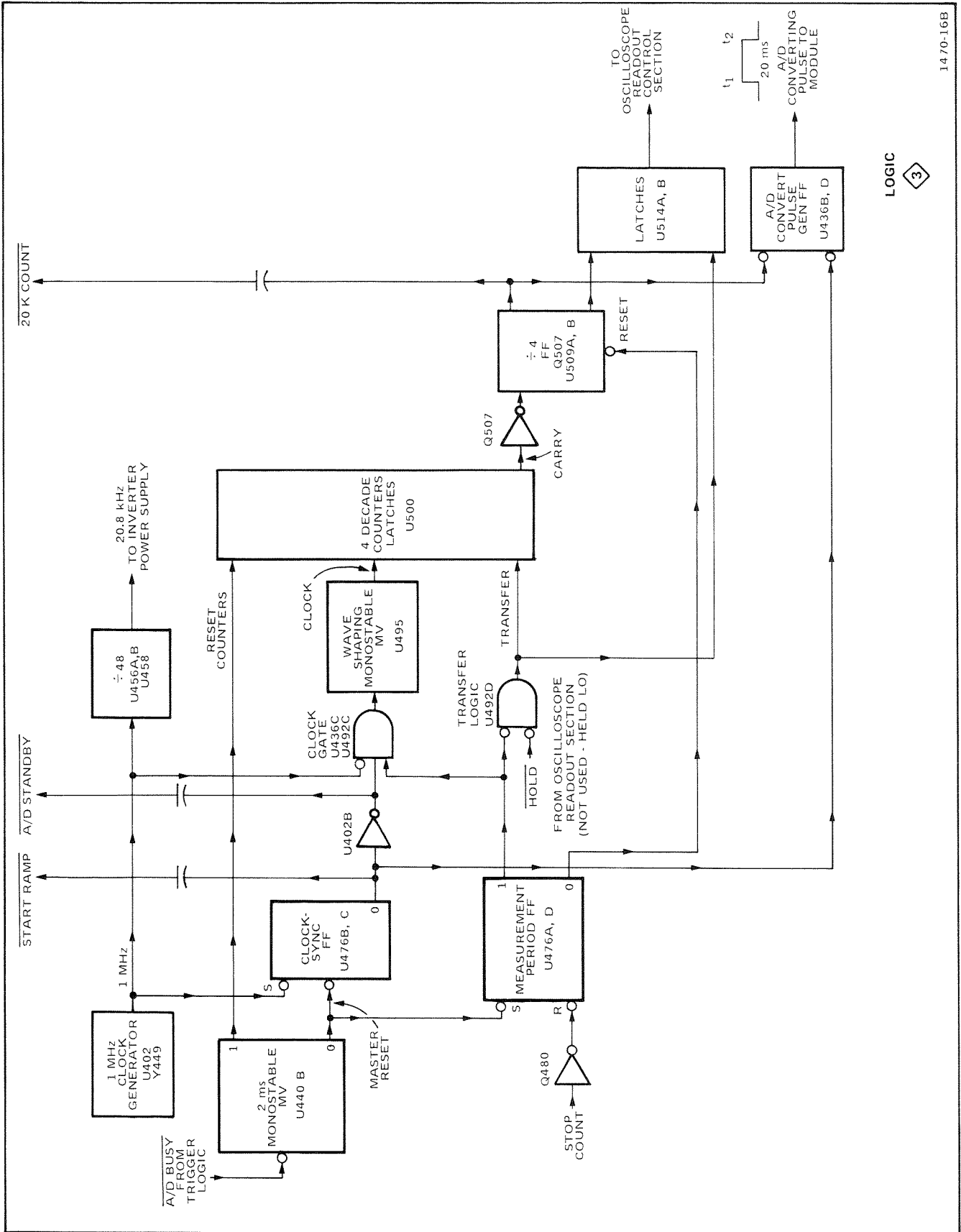

Fig. 2-4B. Block diagram of the 4 1/2 Digit A/D Converter section.

**ENCODING FORMAT**

The 7D12 Readout Logic circuit encodes the Row and Column output lines (pins B37-A37 respectively of the oscilloscope Interface Connector for channel 1, and pins A38-B38 for channel 2) according to the format given in Table 2-1. The time-slot pulses from the oscilloscope readout system are provided to the Readout Logic circuit through the Interface Connector. Several of the time-slot pulses are also connected to address the Multiplexers.

**TABLE 2-1  
7D12 READOUT FORMAT**

Time-Slot Number	Function	Programmed By
TS-1	Determines decimal position	Module
TS-2	Indicates polarity (+ or — symbol) of measurement.	7D12 (Disabled by Module)
	Encodes a > symbol to indicate over-ranging.	7D12
TS-3	Encodes 1 or 2, and blanking of the most significant digit of measurement readout.	7D12
TS-4, TS-5 TS-6, TS-7	Remaining four digits of measurement readout.	7D12
	TS-7 also encodes blanking of the least significant digit of the measurement readout.	Module
TS-8	Symbols	Module
TS-9	Symbols	Module
TS-10	Symbols	Module

**DIGITAL-TO-ANALOG CONVERTER**

Refer to the Readout Logic block diagram shown in Fig. 2-5 throughout the following discussion.

The Digital-to-Analog Converter circuit includes D-A Converters U500, Q540, Q532 and Q552.

Time-slot pulses TS-4, TS-5 and TS-6 from the mainframe are connected to U500 to drive the Output Enable inputs of the D-A Converters. Time slot pulse TS-3 from the mainframe is connected to the emitters of D-A Converters Q540, Q532, and Q552 to provide Output Enable information of the most significant digit. Time-slot pulse, TS-7, encodes Least Significant Digit Blanking, depending upon the module.

**POLARITY AND OVER-RANGE INDICATOR**

The Polarity Enable information to Q524 is determined by the module. Time-slot pulse TS-2 is coupled to Q524 (via switching in the module) to provide the Polarity Enable pulse. If the input to the base of Q524 goes to a lo level, current is added to the Column Current output during TS-2. This added current in TS-2 results in the + symbol being changed to —. TS-2 also enables the Over-Range Indicator. When the output of U514A goes to a lo level, current is added to the Column Current in TS-2. This added current in TS-2 changes either polarity symbol to a > symbol display.

**SCALE FACTOR DISABLE**

The VERTICAL DISPLAY ATTEN switch encodes the module readout system by switching resistors between TS-4 and the module Column output line. The Scale Factor Disable current mixes with the appropriate module time-slot inputs to supply current to the Column output line. The readout system then displays the measurement unit in channel 2 for the combination (7D12 ATTEN switch and module attenuator switch) measurement setting selected.

**THE TEKTRONIX READOUT SYSTEM**

**INTRODUCTION**

The following discussion is provided to acquaint the 7D12 user with the Readout System used in Tektronix 7000-series Oscilloscopes. Since the oscilloscope Readout System provides the digital readout for the 7D12, it is necessary to relate the function of the 7D12 to the Readout System to gain a better understanding of the 7D12 operation. A detailed circuit description of the 7000-series Readout System is given in the oscilloscope instruction manual.

**THE READOUT SYSTEM**

The Readout System in the 7000-series oscilloscopes provides alpha-numeric display of information encoded



## Theory of Operation—7D12 Service

by the plug-in units. This display is presented on the crt, and is written by the crt beam on a time-shared basis with the analog waveform display.

The Readout System produces a pulse train consisting of 10 negative-going pulses called time-slot pulses. These pulses are assigned time-slot numbers corresponding to their relative position in the pulse train. Each time-slot pulse is directed to one of ten output lines, labeled TS-1 through TS-10 (time-slots one through ten) and are connected to the vertical and horizontal plug-in compartments. Two output lines, row and column, are connected from each channel (two channels per plug-in compartment) back to the Readout System.

Data is encoded on these output lines either by connecting resistors between them and the time-slot input lines or by generating equivalent currents. The resultant output is a sequence of analog current levels on the row and column output lines. The row and column current levels are decoded by the Readout System to address a character matrix during each time-slot pulse, thus selecting a character to be displayed or a special instruction to be followed.

## INVERTER POWER SUPPLY

### INVERTER

The block diagram of the Inverter Power Supply is shown in Fig. 2-6. The Inverter is driven with divided-down sync pulses from the 1 MHz Clock Generator. The sync pulses switch  $-15$  volts alternately through the transformer primary to the  $+15$  volt supply at the center tap. The Inverter side of the transformer is referenced to chassis potential.

### FLOATING REGULATORS

The  $+15$  and  $-15$  volt regulator voltages are based upon the  $+5$  volt Reference voltage. The secondary of the transformer and associated circuitry are referenced to floating ground. Each floating regulator circuit is equipped with short-circuit protection. The floating power supply furnishes all the power for the floating portion of the instrument.

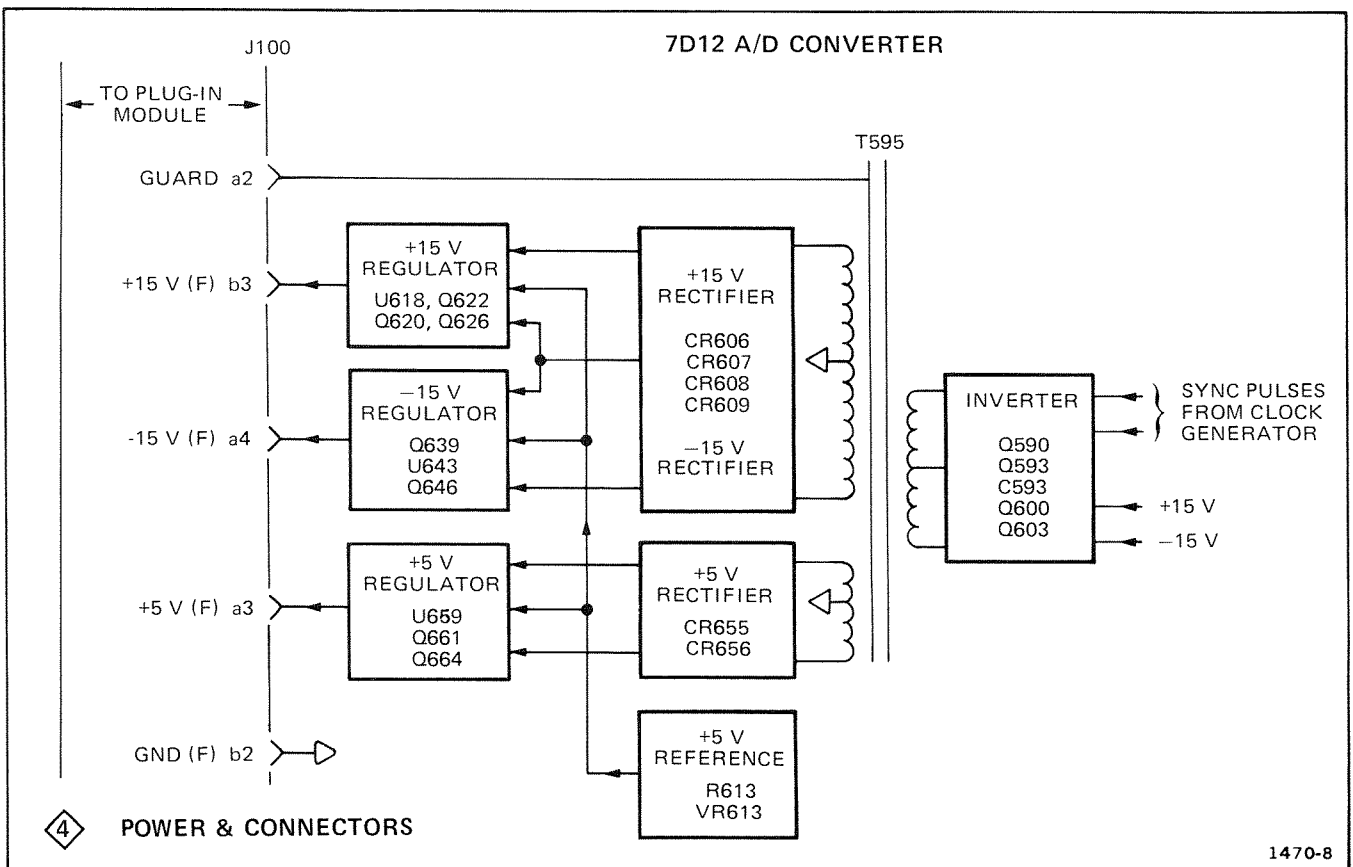

Fig. 2-6. Block diagram of the Inverter Power Supply.

## DUAL-TRACE VERTICAL AMPLIFIER

### GATE AND SIGNAL DISPLAYS

The block diagram for the amplifier is shown in Fig. 2-7. The Gate Display signal is fed directly to CH 1 of the Channel Switch. The Signal Display information passes through an Attenuator to CH 2 of the Channel Switch. Chop or alternate drive pulses (selected by the internal Mode switch) to the Channel Switch is supplied by the mainframe. The switched Gate and Signal Display information pass through the Signal Amplifier to the mainframe to be displayed on the crt.

### TRIGGER PICKOFF

The attenuated Signal Display information passes through a Trigger Amplifier to the mainframe and triggers the time base.

## CIRCUIT OPERATION

### INTRODUCTION

This section provides a detailed description of the electrical operation and relationship of the circuits in the 7D12. The theory of operation for circuits unique to this instrument is described in detail in this discussion.

Circuits commonly used in the electronics industry are not described in detail. If more information is desired on these commonly used circuits, refer to the following textbooks.

Jacob Millman and Herbert Taub, "Pulse, Digital, and Switching Waveforms", McGraw-Hill, New York, 1965.

Robert C. Baron and Albert T. Piccirilli, "Digital Logic and Computer Operations", McGraw-Hill, New York, 1966.

Thomas C. Bartee, "Digital Computer Fundamentals", McGraw-Hill, 1962.

Yaohan Chum, "Digital Computer Design Fundamentals", McGraw-Hill, 1962.

Neil A. Robin, "Analog-To-Pulse-Width Converter Yields 0.1% Accuracy", EDN Journal, Vol. 15, Issue 21, November 1, 1970, page 42.

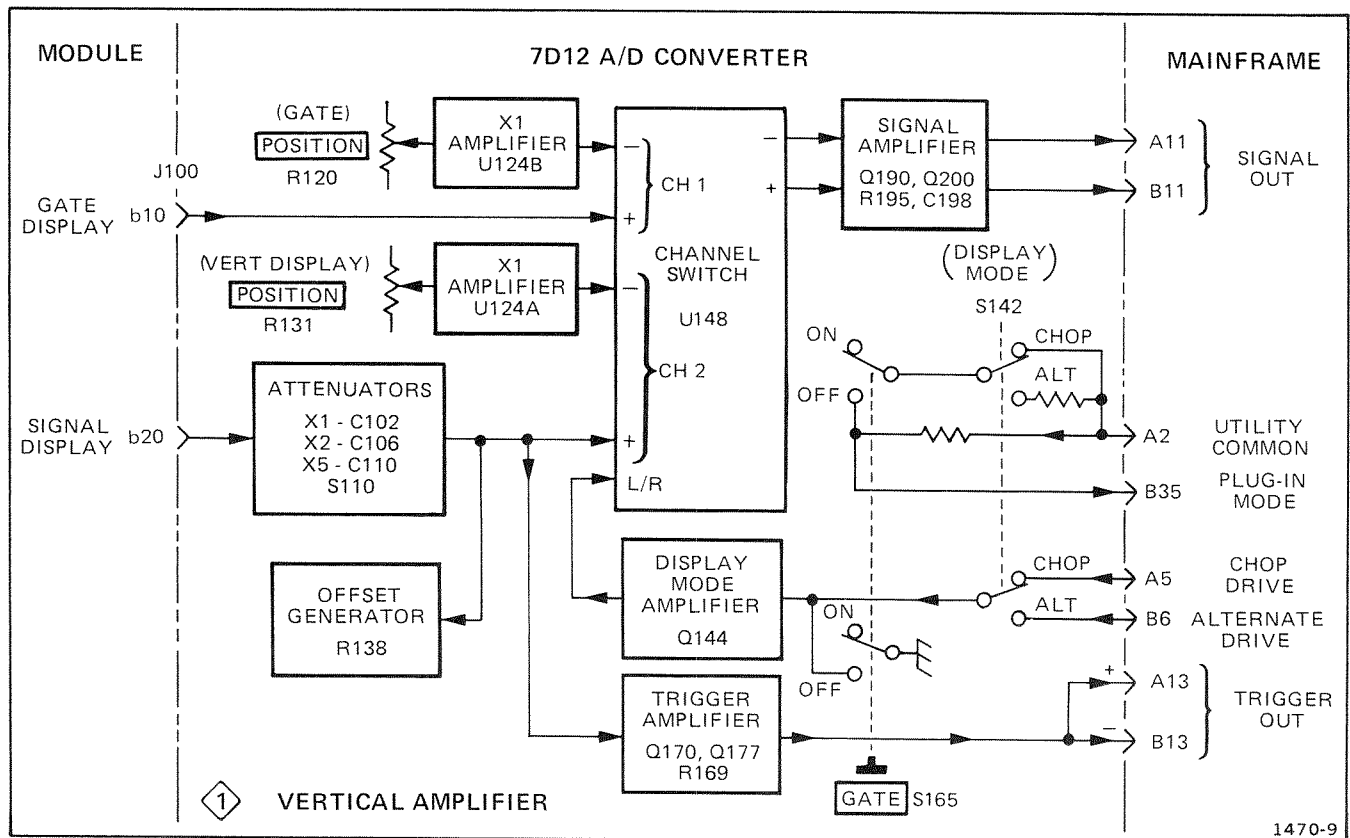

Fig. 2-7. Block diagram of the Dual-Trace Vertical Amplifier section.

## VERTICAL AMPLIFIER

### VERTICAL DISPLAY ATTENUATOR

Module signal display information is coupled to the 7D12 vertical amplifier through pin b20 on J100. Refer to the Vertical Amplifier diagram 1 in Section 6. The signal display passes through an attenuator network (selected by ATTEN switch S110) to the amplifier circuitry. The ATTEN switch is a rotary-cam type and is shown in the 1X (unity gain) position. Module signal display output voltage to the CH 2 vertical amplifier are standardized in the 1X ATTEN switch position. The 2X and 5X positions are referenced to the 1X attenuator network. Each attenuator network presents a 1 kilohm load to the signal display output in the module. High-frequency compensation adjustments C102, C106 and C110 are adjusted to minimize front corner rolloff and peaking. The CH 2 high-frequency compensation network connects to pins 8 and 9 of U148.

### DISPLAY OFFSET

The signal display passes from the attenuator network to one side of the CH 2 differential amplifier (pin 7, U148). The other side of the differential amplifier (pin 10, U148) connects to the VERTICAL DISPLAY POSITION control, R131. The POSITION control, R131, supplies a variable dc voltage to the no-signal side of the differential amplifier, allowing vertical trace positioning. With no-signal input, U148 pin 7 draws a small amount of current through R105, R109 or R112 depending upon the ATTEN switch setting. The resulting voltage drop across these resistors can cause vertical trace shift as the ATTEN switch setting is changed. Display Offset adjustment R138 is set to supply U148 pin 7 with the required current. When properly set, R105, R109 and R112 will have zero voltage drop.

### TRIGGER LEVEL

A pickoff of the attenuated signal display information is amplified by Q170 and Q177. The base of Q170 and the collector of Q177 should be zero volts during a no-signal-in condition. The amplifier is balanced by setting the Q177 collector (TP177) to zero volts using the Trig Level adjustment R169. In the balanced condition signal display information to the base of Q170 will have equal amplitude in the positive- and negative-going excursions to internally trigger the time base.

### GATE DISPLAY

Gate display information from the module is coupled to the vertical amplifier through pin b10 on J100. The gate display signal passes through voltage divider R128, R127 and transformer T125 to one side of differential amplifier.

The other side of the differential amplifier (pin 2, U148) connects through T125 to the GATE POSITION control R120. GATE POSITION control R120 supplies a variable dc voltage to the no-signal side of the differential amplifier, allowing gate trace positioning. Transformer T125 allows the differential amplifier to operate push-pull at the higher frequencies thereby reducing front-corner degeneration. GATE DISPLAY switch S165 is the ON position couples pin 4 of U148 to the channel switching signals from the mainframe. The CH 1 high-frequency compensation network connects to pins 1 and 16 of U148.

### DISPLAY MODES

The GATE switch (S165) ON position connects the internal Display Mode switch, S142, to the mainframe chop and alternate drive signals which couple to pin 4 of U148. The output of U148 (pins 12 and 13) will either chop or alternate between CH 1 (pins 2 and 15) and CH 2 (pins 7 and 10) depending on the Display Mode switch setting. GATE switch S165, in the OUT-OFF position, holds pin 4 of U148 high allowing CH 2 only to pass.

### VERTICAL AMPLIFIER OUTPUT

Channel Switch U148, pins 12 and 13, is connected to the output amplifier Q190 and Q200. Voltage dividers R205, R206, and R215, R216 present an output impedance of 50 ohms to the mainframe. Refer to Table 2-2.

TABLE 2-2

U148 INPUT/OUTPUT TABLE FOR CH 1 AND CH 2 DISPLAY MODES

INPUT	OUTPUT
DISPLAY MODE SIGNAL 4	VERTICAL OUTPUT SIGNAL 12, 13
LO	CH 1 and CH 2 Chopped or Alternating
HI	CH 2



## 4-1/2 DIGIT A/D CONVERTER

### $|G_m|$ CONVERTER

Module analog information to be measured enters the 7D12 A/D Converter through pins J ( $V_{hi}$ ) and N ( $V_{lo}$ ) of J100. Refer to the 4-1/2 Digit A/D Converter diagram 2 in Section 6. Dual-diode CR226 protects the  $|G_m|$  Converter input transistor Q244 and electronic switches Q233-Q237 from voltage transients. The  $V_{hi}$  or  $V_{lo}$  input to Q244 is selected by electronic switches Q233 and Q237. The electronic switch gating voltages from Q313 and Q306 are neutralized by capacitor C235, thereby preventing gating noise from entering the  $|G_m|$  Converter. The source bias of JFET Q244 is set to +195 mV with Fet Bias adjustment R249 through U248B and Q246. The +195 mV bias level prevents Q244 from conducting during the no-signal-input condition. Transistors Q242-Q250-Q252-Q254-Q246-U248A and B provide the current source for JFETs Q244 and Q262. Q244 and Q262 present a high impedance to the input signal. When the output of U260 goes positive, Q267 turns on, opening a current path through R269-CR279-U276. When the output of U260 goes negative Q270 turns on, opening a current path through CR263-R269-U260. Resistor R269 determines the conversion of voltage to current. The output of the  $|G_m|$  Converter (drains of Q267 and Q270) is connected to electronic switch CR338 and CR339.

### AUTO-ZEROING CIRCUIT

The output of U260 is amplified by U283 and connects to the input of the Auto-Zeroing Circuit U301. Offset Voltage Storage Capacitor C302 stores the offset voltage of the  $|G_m|$  Converter. Refer to the Timing Diagram in Fig. 2-3 for sequence of events. Electronic switch Q290 is open between  $t_0$  and  $t_2$ , allowing C302 to hold the output of U283 and U276 at the predetermined offset level. Q275 provides a high-impedance input to U276.

### READOUT POLARITY

The output of U260 couples through R265 to the input of U283. The output of U283 drives the base of Q287, thereby allowing current to flow through the light-emitting diode portion of U289. Current through the diode generates the — polarity information. The + polarity information is generated when the diode is not conducting.

### REFERENCE CURRENT GENERATOR

The emitter current of Q353 is held constant by VR350 and U351, thereby holding the input of U356 at a constant

voltage. The output of U356 drives JFET Q363 allowing current to flow through series resistors T362-R361-R360 and R359. A/D Gain adjustment R361 sets the current necessary to discharge C379 in a given period of time; therefore, the A/D Gain adjustment determines the value of readout display for a given input voltage.

### INTEGRATOR-COMPARATOR

JFET Q367 provides a high-impedance input to the Integrator amplifier U375. Q369 is the current source for Q367. Q376 and Q378 provide amplification at the higher frequencies. The collector of Q378 connects to the input of Comparator U380. The output of U380 is fed back through R383 to electronic switch Q336. Q336 is on before  $t_0$ , connecting the output of Comparator U380 to the Integrator input, Q367. At  $t_0$ , Q336 turns off allowing the Integrator to start at zero volts. The output of the  $|G_m|$  Converter (Q267 and Q270) begins charging capacitor C379 at  $t_1$ . At  $T_2$  the counters send a negative-going 20K Count pulse to T326. The resultant negative-going 20K Count pulse from the collector of Q329 clears U317A, thereby changing the states of electronic switches Q313 and Q306. Q233 turns off and Q237 turns on disconnecting  $V_{hi}$  from Q244. Q290 turns on allowing the Auto-Zeroing Circuit, Q296-Q298-U301, to null the  $|G_m|$  Converter inputs.

## LOGIC

### 60 MILLISECOND MULTIVIBRATOR

Refer to the Logic diagram 3 in Section 6. A positive-going A/D Convert Command from the module turns on Q434. The result  $I_0$  input signal to pin 1, U436A, allows pin 3 to go hi. Monostable multivibrator Q440A output changes state for a period of 60 milliseconds. The measurement rate can be adjusted from one to approximately four measurements per second by the setting of Trig Rate adjustment R441. The negative-going 60 millisecond pulse is coupled to pin 9, U440B, and to TRIG'D indicator CR438.

### 2 MILLISECOND MULTIVIBRATOR

The negative-going 60 millisecond pulse from pin 4, U440A, is coupled to monostable multivibrator U440B, pin 9. The output of U440B changes state for a period of 2 milliseconds. A positive-going 2 mS pulse from U440B, pin 5, resets U500. A negative-going 2 mS pulse from U440B, pin 12, is coupled to Clock Sync ff U476C.

## Theory of Operation—7D12 Service

### 1 MHz CLOCK

The 1 megahertz clock signal is generated by U402D, F and Y449. U402E is a buffer stage. The clock signal passes through U456A ( $\div 2$ ), U458 ( $\div 12$ ) and U456 ( $\div 2$ ) to synchronize the Floating Power Supply Inverter at a frequency of 20.8 kHz. The clock signal also connects to Clock Sync ff U476B.

### CLOCK SYNCHRONIZATION

A negative-going 2 millisecond pulse from U440B, pin 12 is coupled to U476C, pin 10. After 2 milliseconds, the pulse to U476C pin 10 goes positive. The next positive-going pulse to U476B pin 5 changes the output state of U476B and U476C, thus generating a pulse to the Start Ramp and A/D Converting Pulse outputs. U402B inverts the pulse for an A/D Stansby pulse output.

### MEASUREMENT PERIOD

At  $t_3$  (refer to Fig. 2-3) a Stop Count pulse through Q480 resets U476A and D which turns off U436C, thereby shutting off the clock pulses to the counters.

### COUNTERS AND LATCHES

The clock pulses pass through wave-shaping monostable multivibrator U495 to the counters U500. At  $t_1$ , the Stop Count pulse through U476A and D enables AND gate U492D (pin 11, U492D is held lo throughout the timing cycle). The output of U492D generates a pulse to transfer the contents of the counters (10K count carry pulse) through Q507 to enable U509A. The second 10K count carry pulse enables U509B, which generates a 20K count pulse output at pin 8. At  $t_2$ , the output of U492D is coupled to the memories, U514A and B. A Stop Count pulse from pin 13, U492D (through U500), transfers the contents of U509A and B to memories U514A and B. U492B and Q540 will blank the most significant digit when that digit is zero. Q552 provides the first significant digit information, numerals 1 or 2. Q547 provides the overrange (>) information to the column output line.

Column Current adjustment R499 sets the U500,  $A_{in}$ , output current. The U500,  $A_{in}$ , output current determines the Column current to the mainframe readout circuit.

At  $t_3$  the 20K Count pulse enables U492A and pin 6 of U514C samples the polarity information. At hi input at U514C pin 6 turns on Q524 and the Polarity Enable goes lo providing a + readout information to the mainframe readout circuit.

## LOGIC TRIGGERING

### SINGLE SWEEP RESET

The Single Sweep Reset pulse from the mainframe couples through inverter U402C to amplifier Q404. A negative-going input pulse to U402C turns on Q404 providing a single positive trigger pulse to the module.

### AUTO TRIGGERING

Free-running oscillator Q410 provides a continuous 4 Hz trigger signal to the module in the AUTO TRIGGERING mode.

### EXT AND MAN TRIGGERING

An externally generated trigger signal is allowed to pass directly to the module in the EXT TRIGGERING mode. Manual triggering the 7D12 discharges capacitor C419 through resistor R420 to provide a single trigger pulse.

## POWER AND CONNECTORS

### FLOATING POWER SUPPLY

Inverter Circuit Q590, Q593 and Q600, Q603 is driven with a 20.8 kHz differential synchronous signal from the Clock Generator. Refer to the Power and Connectors diagram 4 in Section 6. Power to the inverter is supplied by the mainframe +15 and -15 volt supplies.

The differential synchronous clock signals are coupled to the bases of Q590 and Q600 through J587 and J597. The collectors of Q593 and Q603 alternately supply -15 volts to each end of the primary of transformer T595, which returns to +15 volts at the center tap.

Inverter signal noise generated in the power supply circuit is neutralized via feedback capacitors C603, C604 and C594, C593. Inverter Sig Neut adjustment C593 is adjustable to minimize the inverter pulse amplitude on the floating ground.

The square-wave inverter signal is rectified and filtered in the floating section of the power supply. Diodes CR606, CR607, CR608 and CR609 rectify current for the Floating +15 and -15 volt Supplies. CR655 and CR656 rectify current for the Floating +5 Volt Supply.

The +5 volt reference voltage is determined by voltage divider R611-R612-R613, R614, which is connected between floating +15 volts and floating ground. Temperature-compensated zener diode VR613 maintains a constant 9 volt drop across R612, R613 and R614.

The Floating +15 and —15 Volt Regulator voltages are based on the +5 volt reference voltage. The +5 volt reference accuracy is set to +5 volts within 10 mV, with adjustment R613. Each regulator circuit has short-circuit protection.

### +15 Volt Regulator

Current flows from the floating +15 volt output through voltage divider R629 and R628 to floating ground. The resultant voltage drop across the divider sets U618 pin 3 at +5 volts. Voltage divider R629 and R628 determine the output voltage accuracy. Any attempted output voltage change in the +15 volt supply appears at U186 pin 3, thus changing the output level at pin 6. The regulator output at pin 6 drives the base of Darlington pair Q620 and Q622 to supply a voltage-regulating current. Q626 provides short-circuit protection for the + volt regulator circuit. Q626 is on, during normal operation, connecting pin 4 of U618 ( $V_{cc-}$ ) to floating ground. If the output level drops below +3.5 volts, Q626 turns off, thereby disabling the supply.

### —15 Volt Regulator

Current flows from the —15 volt output through R640 and R641 to the +5 volt reference voltage. The resultant voltage drop across the divider sets U643 pin 3 at zero volts. Any attempted output voltage change in the —15 volt supply appears at pin 3 of U643, thus changing the output level at pin 6. The regulator output at pin 6 of U643 drives the base of Q646 to supply voltage-regulating current. Q639 and VR637 provide short-circuit protection for the —15 volt supply. Q639 and VR637 are off during normal operation. If the output voltage goes positive to —3 volts or more, VR637 conducts turning on Q639 and reduces the +5 volt reference voltage to about —17 volts. The output level at U643 pin 6 is reduced, turning off current output transistor Q646.

### +5 Volt Regulator

Any attempted output voltage change in the floating +5 volt supply appears at pin 3 of U659, thus changing the output level at pin 6. The regulator output at U659 pin 6 drives the base of Q661 to supply voltage-regulating current. Q664 provides short-circuit protection for the +5 volt regulator circuit. Q664 is on during normal operation connecting ( $V_{cc}$ ) U659 pin 4 to floating ground. If the +5 volt output level drops below +0.7 volt, Q664 turns off to disable the supply.



# MAINTENANCE

## INTRODUCTION

This section of the manual contains maintenance information for use in preventive maintenance, corrective maintenance and trouble shooting of the 7D12.

Further maintenance information relating to general maintenance can be found in the instruction manuals for the 7000-series oscilloscopes.

## PREVENTIVE MAINTENANCE

### INTRODUCTION

Preventive maintenance, consisting of cleaning, visual inspection, etc., performed on a regular basis, will ensure the reliability of this instrument. Periodic checks of the semiconductor devices used in this unit are not recommended as a preventive maintenance measure.

### CLEANING

The 7D12 should be cleaned as often as operating conditions require. Accumulation of dirt in the instrument can cause overheating and component breakdown. Dirt on components acts as an insulating blanket and prevents efficient heat dissipation. It also provides an electrical conduction path which may result in instrument failure. The side panels provide protection against dust in the interior of the instrument. Operation without the panels in place necessitates more frequency cleaning.



*Avoid the use of chemical cleaning agents which might damage the plastics used in this instrument. In particular, avoid chemicals which contain benzene, toluene, xylene, acetone or similar solvents. Recommended cleaning agents are isopropyl alcohol or Kelite (1 part Kelite, 20 parts water).*

### Front Panel

Loose dust may be removed with a soft cloth or a dry brush. Water and mild detergent may be used. However, abrasive cleaners should not be used.

### Interior

Cleaning the interior of the unit should precede calibration, since the cleaning process could alter the settings of the calibration adjustments. Use low-velocity compressed air to blow off the accumulated dust. Hardened dirt can be removed with a soft dry brush, cotton-tipped swab, or cloth dampened with mild detergent and water solution.

### Lubrication

The reliability of potentiometers, switches and other moving parts can be maintained if they are kept properly lubricated. However, over-lubrication is as detrimental as too little lubrication.

Use a cleaning-type lubricant on shaft bushings, interconnecting plug contacts and switch contacts. Lubricate switch detents with a heavier grease. A lubrication kit containing the necessary lubricating materials and instructions is available through any Tektronix Field Office. Order Tektronix Part Number 003-0342-00.

### VISUAL INSPECTION

The 7D12 should be inspected occasionally for such defects as broken connections, improperly seated semiconductors, damaged or improperly installed circuit boards and heat-damaged parts.

The corrective procedure for most visible defects is obvious. However, particular care must be taken if heat-damaged components are found. Overheating usually indicates other trouble in the instrument; therefore, it is important that the cause of overheating be corrected to prevent recurrence of the damage.

### RECALIBRATION

To ensure accurate measurements, check the calibration of this instrument after each 1000 hours of operation or every six months if used infrequently. In addition, replacement of components may necessitate recalibration of the affected circuits. The calibration procedure can also be helpful in localizing certain troubles in the instrument. In some cases, minor troubles may be revealed and/or corrected by recalibration.

## TROUBLESHOOTING

### INTRODUCTION

The following information is provided to facilitate troubleshooting of the 7D12. Information contained in other sections of this manual should be used along with the following information to aid in locating the defective component. An understanding of the circuit operation is very helpful in locating troubles, particularly where integrated circuits are used.

### TROUBLESHOOTING AIDS

#### Diagrams

Circuit diagrams are given on foldout pages in Section 6. The circuit number and electrical value of each component in this instrument are shown on the diagrams.

#### Circuit Boards

The circuit boards used in the 7D12 are outlined on the schematic diagrams, and layout drawings of the boards are shown adjacent to the associated schematic diagram. Each board-mounted electrical component is identified on the drawing of its circuit number.

#### Component and Wiring Color Code

Colored strips or dots on resistors and capacitors signify electrical values, tolerances, etc., according to EIA standard color code. Components not color-coded usually have the value printed on the body.

The insulated wires used for interconnection in the 7D12 are color-coded to facilitate tracing wires from one point to another in the unit.

#### Semiconductor Lead Configurations

The lead configurations of most semiconductor devices used in this instrument are shown on the foldout preceding the schematic diagrams. Individual special semiconductor configurations are shown on the schematic diagram adjacent to its component symbol.

### TROUBLESHOOTING EQUIPMENT

The following equipment is useful for troubleshooting the 7D12.

1. Semiconductor Tester — Some means of testing the transistors, diodes, fet's used in this instrument is helpful. A transistor-curve tracer such as the Tektronix 576 Curve Tracer will give the most complete information.

2. Multimeter — A voltmeter is required for checking voltages within the circuits, and an ohmmeter for checking fuse continuity, and resistance values.

3. Test Oscilloscope — A test oscilloscope is required to view waveforms at different points in the circuit. A Tektronix 7000-series mainframe equipped with a readout system, 7D13 Digital Multimeter unit, 7B-series Time-Base unit and a 7A-series amplifier unit with a 10X probe will meet the needs of both items 2 and 3.

4. Plug-in Extender — A fixture that permits operation of the unit outside of the plug-in compartment for better accessibility during troubleshooting. Order Tektronix Part Number 067-0589-00.

5. Test Module — A fixture that permits direct signal coupling to the vertical display, gate input or analog-to-digital circuitry in the 7D12. Order Tektronix Part Number 067-0700-00.

### TROUBLESHOOTING PROCEDURE

This troubleshooting procedure is arranged in an order which checks the simple trouble possibilities before proceeding with extensive troubleshooting.

#### 1. Check Control Settings

An incorrect setting of the 7D12 controls can indicate a trouble that does not exist. If there is any question about the correct function or operation of a control or front-panel connector, see the Operating Information section.

#### 2. Check Associated Equipment

Before proceeding with troubleshooting of the 7D12 check that the equipment used with this instrument is operating correctly. If possible substitute an A/D Converter unit known to be operating correctly into the indicator unit and see if the problem persists. Check that the input signals are properly connected and that the interconnecting cables are not defective.

### 3. Visual Check

Visually check the portion of the instrument in which the trouble is suspected. Many troubles can be located by visual indications, such as unsoldered connections, broken wires, damaged circuit boards, damaged components, etc.

### 4. Check Instrument Performance

Check the calibration of the unit or the affected circuit, by performing Part I-Performance Check of Section 4. The apparent trouble may only be a result of misadjustment, and may be corrected by calibration. Complete calibration instructions are given in Section 4, Part II-Calibration.

### 5. Check Voltages and Waveforms

Often the defective component can be located by checking for the correct voltage or waveform in the circuit.

### 6. Check Individual Components

The following procedures describe methods of checking individual components in the 7D12. Components that are soldered in place are best checked by first disconnecting one end. This isolates the measurement from the effects of surrounding circuitry.



*Power switch must be turned off before removing or replacing semiconductors.*

**SEMICONDUCTORS.** A good check of transistor operation is actual performance under operating conditions. A transistor can be most effectively checked by substituting a new component for it (or one which has been checked previously). However, be sure that circuit conditions are not such that a replacement transistor might also be damaged. If substitute transistors are not available, use a dynamic tester. Static-type testers are not recommended, since they do not check operation under simulated operating conditions.

IC's (integrated circuits) can be checked with a voltmeter, test oscilloscope, or by direct substitution. A good understanding of circuit operation is essential to troubleshooting circuits using IC's. Use care when checking voltages and waveforms around the IC's so that adjacent leads are not shorted together. A convenient means of clipping a test probe to the 14- and 16-pin IC's is

with an IC test clip. This device also doubles as an extraction tool. The lead configuration for the semiconductors used in this instrument are shown on the diagrams preceding the diagrams section.

Diodes can be checked for an open or shorted condition by measuring the resistance between terminals. With an ohmmeter scale having an internal source of between 800 millivolts and 3 volts, the resistance should be very high in one direction and very low when the meter leads are reversed.



*Do not use an ohmmeter scale that has a high internal current. High currents may damage the diode.*

The cathode end of each glass-encased diode is indicated by a stripe, a series of stripes or a dot. For most silicon or germanium diodes with a series of stripes, the color-code identifies the three significant digits of the Tektronix Part Number using the resistor color-code system (e.g., a diode color-code pink-, or blue-, brown-gray-green indicates Tektronix Part Number 152-0185-00). The cathode and anode ends of metal-encased diodes can be identified by the diode symbol marked on the body.

**RESISTORS.** Check the resistors with an ohmmeter. See the Electrical Parts List for the tolerance of the resistors used in this instrument. Resistors normally do not need to be replaced unless the measured value varies widely from the specified value.

**INDUCTORS.** Check for open inductors by checking continuity with an ohmmeter. Shorted or partially shorted inductors can usually be found by checking the waveform response when high-frequency signals are passed through the circuit. Partial shorting often reduces high-frequency response (roll-off).

**CAPACITORS.** A leaky or shorted capacitor can best be detected by checking resistance with an ohmmeter on the highest scale. Do not exceed the voltage rating of the capacitor. The resistance reading should be high after initial charge of the capacitor. An open capacitor can best be detected with a capacitance meter or by checking if the capacitor passes AC signals.

## Maintenance—7D12 Service

### 7. Repair and Readjust the Circuit

If any defective parts are located, follow the replacement procedures given in this section. Be sure to check the performance of any circuit that has been repaired or had any electrical components replaced.

## CORRECTIVE MAINTENANCE

### GENERAL

Corrective maintenance consists of component replacement and instrument repair. Special techniques required to replace components in this instrument are given here.

### OBTAINING REPLACEMENT PARTS

#### Standard Parts

All electrical and mechanical part replacements for the 7D12 can be obtained through your local Tektronix Field Office or representative. However, many of the electronic components can be obtained locally in less time than is required to order them from Tektronix, Inc. Before purchasing or ordering replacement parts, check the parts list for value, tolerance, rating and description.

#### NOTE

*When selecting replacement parts, it is important to remember that the physical size and shape of a component may affect the performance of the instrument, particularly at high frequencies. All replacement parts should be direct replacements unless it is known that a different component will not adversely affect instrument performance.*

#### Special Parts

In addition to the standard electronic components, some special parts are used in the 7D12. These parts are manufactured or selected by Tektronix, Inc. in accordance with our specifications. See Cross Index Mfr. Code Number to Manufacturer in the Parts List. Most of the mechanical parts used in this instrument have been manufactured by Tektronix, Inc. Order all special parts directly from your local Tektronix Field Office or representative.

### Ordering Parts

When ordering replacement parts from Tektronix, Inc., include the following information:

1. Instrument Type.
2. Instrument Serial Number.
3. A description of the part (if electrical, include circuit number).
4. Tektronix Part Number.

### SOLDERING TECHNIQUES

#### WARNING

*Disconnect the instrument from the power source before soldering.*

The reliability and accuracy of this instrument can be maintained only if proper soldering techniques are used when repairing or replacing parts. General soldering techniques which apply to maintenance of any precision electronic equipment should be used when working on this instrument. Use only 60/40 rosin-core, electronic-grade solder. The choice of soldering iron is determined by the repair to be made. When soldering on circuit boards, use a 35- to 40-watt pencil-type soldering iron with a 1/8-inch wide, wedge-shaped tip. Keep the tip properly tinned for best heat transfer to the solder joint. A higher wattage soldering iron may separate the wiring from the base material. Avoid excessive heat; apply only enough heat to remove the component or to make a good solder joint. Also, apply only enough solder to make a firm solder joint; do not apply too much solder.

#### CAUTION

*The circuit boards in this instrument are multi-layer type boards with a conductive path(s) laminated between the top and bottom board layers. All soldering on these boards should be done with extreme care to prevent breaking the connections to the center conductor(s); only experienced maintenance personnel should attempt repair of these boards.*



For metal terminals, (e.g., switch terminals, potentiometers, etc.) a higher wattage-rating soldering iron may be required. Match the soldering iron to the work being done. For example, if the component is connected to the chassis or other large heat-radiating surface, it will require a 75-watt or larger soldering iron. The pencil-type soldering iron used on the circuit board can be used for soldering to switch terminals, potentiometers, or metal terminals mounted in plastic holders.

## COMPONENT REPLACEMENT

### Semiconductor Replacement

Transistors should not be replaced unless actually defective. If removed from their sockets during routine maintenance, return them to their original sockets. Unnecessary replacement of transistors may effect the calibration of this instrument. When transistors are replaced, check the performance of the part of the instrument which may be affected.

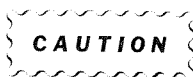

*POWER switch must be turned off before removing or replacing semiconductors.*

Replacement semiconductors should be of the original type or a direct replacement. The lead configuration of the semiconductors used in this instrument are shown preceding the diagram section. Some plastic case transistors have lead configurations which do not agree with those shown here. If a replacement transistor is made by a different manufacturer than the original, check the manufacturer's basing diagram for correct basing. All transistor sockets in this instrument are wired for the standard basing used for metal-case transistors. Transistors which have heat radiators or are mounted on chassis use silicone grease to increase heat transfer. Replace the silicone grease when replacing these transistors.



*Handle silicone grease with care. Avoid getting silicone grease in the eyes. Wash hands thoroughly after use.*

An extracting tool should be used to remove the 14- and 16-pin integrated circuits to prevent damage to the pins. This tool is available from Tektronix, Inc. Order

Tektronix Part Number 003-0619-00. If an extracting tool is not available when removing one of these integrated circuits, pull slowly and evenly on both ends of the device. Try to avoid having one end of the integrated circuit disengage from the socket before the other, as the pins may be damaged.

### Interconnecting Pin Replacement

Two methods of interconnection are used in this instrument to connect the circuit boards with other boards and components. When the interconnection is made with a coaxial cable, a special end-lead connector plugs into a socket on the board. Other interconnections are made with a pin soldered onto the board. Two types of mating connections are used for these interconnecting pins. If the mating connector is on the end of a lead, an end-lead pin connector is used which mates with the interconnecting pin. The following information provides the replacement procedure for the various types of interconnecting methods.

**COAXIAL-TYPE END LEAD CONNECTORS.** Replacement of the coaxial-type, end-lead connectors requires special tools and techniques; only experienced maintenance personnel should attempt replacement of these connectors. It is recommended that the cable or wiring harness be replaced as a unit. For cable or wiring harness part numbers, see the Mechanical Parts List. An alternative solution is to refer the replacement of the defective connector to your local Tektronix Field Office or representative.

#### NOTE

*A circuit-board pin replacement kit including necessary tools, instructions, and replacement pins is available from Tektronix, Inc. Order Tektronix Part Number 040-0542-00.*

**CIRCUIT-BOARD PINS.** To replace a pin which is mounted on a circuit board, first disconnect any pin connectors. Then, unsolder the damaged pin and pull it out of the circuit board with a pair of pliers. Be careful not to damage the wiring on the board with too much heat. Ream out the hole in the circuit board with a 0.031-inch drill. Remove the ferrule from the new interconnecting pin and press the new pin into the hole in the circuit board. Position the pin in the same manner as the old pin. Then, solder the pin on both sides of the circuit board. If the old pin was bent at an angle to mate with a connector, bend the new pin to match the associated pins.

**CIRCUIT BOARD PIN SOCKETS.** The pin sockets on the circuit boards are soldered to the rear of the board. To

## Maintenance—7D12 Service

replace one of these sockets, first unsolder the pin (use a vacuum-type desoldering tool to remove excess solder). Then straighten the tabs on the socket and remove it from the hole in the board. Place the new socket in the circuit board hole and press the tabs down against the board. Solder the tabs of the socket to the circuit board; be careful not to get solder into the socket.

### NOTE

*The spring tension of the pin sockets ensures a good connection between the circuit board and the pin. This spring tension can be destroyed by using the pin sockets as a connecting point for spring-loaded probe tips, alligator clips, etc.*

**END-LEAD PIN CONNECTORS.** The pin connectors used to connect the wires to the interconnecting pins are clamped to the ends of the associated leads. To replace damaged end-lead pin connectors, remove the old pin connector from the end of the lead and clamp the replacement connector to the lead.

Some of the pin connectors are grouped together and mounted in a plastic holder; the overall result is that these connectors are removed and installed as a multi-pin connector. To provide correct orientation of this multi-pin connector when it is replaced, an arrow is stamped on the circuit board and a matching arrow is molded into the plastic house of the multi-pin connector. Be sure these arrows are aligned as the multi-pin connector is replaced. If the individual end-lead pin connectors are removed from the plastic holder, note the color of the individual wires for replacement.

### CIRCUIT BOARD REPLACEMENT

If a circuit board is damaged beyond repair, replace the entire assembly including all soldered-on components. Part numbers for completely wired circuit boards are given in the Mechanical Parts List.

The Triggering switch board is mounted on the front panel, and the Floating Board is mounted as a sub-assembly on the back of the mainboard; pin connectors are used for most interconnections with other circuit boards and components. Use the following procedure to remove the subassemblies and panel-mounted circuit boards.

The location of the pin connectors is shown on the circuit board illustrations in the diagrams section. Correct orientation of multi-pin connections is indicated by an

arrow molded into the connector housing (pin 1); a matching arrow is marked on the circuit board. Be sure these arrows are aligned as the multi-pin connector is replaced.

**A2—FLOATING BOARD.** Remove the Floating circuit board as follows:

1. Disconnect both cable connectors from the Floating circuit board.
2. Remove all four screws holding the Floating board to mounting surface.
3. Remove the board from the unit.
4. Replace the Floating board in reverse order of removal. Match all pins on mounting surface with holes in the Floating board. Cables can be connected to either connector.

**A1—MAINBOARD.** Remove main circuit board as follows:

1. Remove the Floating board as outlined in previous procedure.
2. Remove all four springs and shield from the backside of the mainboard.
3. Loosen hex-socket screws on the attenuator switch and POSITION control knobs. Remove both knobs.
4. Disconnect all cables and multi-pin connectors from the circuit board. Remove the cable hold-down screw.
5. Remove both screws securing top edge of the circuit board and single screw from lower end of module connector.
6. Remove the four screws securing rear bracket. Lift top plate slightly and pull circuit board out.
7. Remove rear bracket from Main circuit board using small screwdriver to lift retainers.

8. Reassemble in reverse order of removal. Insert rear bracket screw with spacer on upper left corner as viewed from instrument rear.

A3—TRIGGERING SWITCH BOARD. Remove Triggering Switch circuit board as follows:

1. Loosen hex-socket screws on attenuator switch and POSITION control knobs. Remove both knobs.
2. Remove GATE POSITION knob (pull straight back).
3. Remove the two nuts on rear of front panel using a 5/16-inch open-end wrench. Remove front panel.
4. Make a color-code wiring sketch of the eight wires and cables that connect to the Triggering switch circuit board. Unsolder these wires from circuit board.
5. Unscrew Triggering switch securing screws from sub panel. Remove switch and plastic LED (TRIG'D indicator) spacer from sub panel.
6. Replace defective switch by replacing entire board with switch attached. Reverse order of above procedure to re-install Triggering switch board assembly, front panel, knobs and other parts that have been removed.

**SWITCH REPLACEMENT**

Several types of switches are used in the 7D12. The Triggering or Gate switches should be replaced as a unit if damaged. The following special maintenance information is provided for the cam-type (Attenuator) switch.



*Repair of cam-type switches should be undertaken only by experienced maintenance personnel. Switch alignment and spring tension of the contacts must be carefully maintained for proper operation of the switch. For assistance in maintenance of cam-type switches, contact your local Tektronix Field Office or representative.*

CAM-TYPE SWITCH. Disassemble VERTICAL DISPLAY ATTEN cam-type switch as follows:

*NOTE*

*A cam-type switch repair kit including necessary tools, instructions, and replacement contacts is available from Tektronix, Inc. Order Tektronix Part Number 040-0541-00.*

The VERTICAL DISPLAY ATTEN cam-type switch consists of a rotating cam, which is turned by the front-panel knobs and a set of contacts mounted on an adjacent circuit board. These switch contacts are actuated by lobes on the cam.

1. Remove Floating board, springs and shield as described previously.
2. Loosen setscrews securing potentiometer shaft (VERTICAL DISPLAY POSITION control) to extension rod. Remove extension rod and knob.
3. Loosen setscrews securing Attenuator switch knob. Remove knob.
4. Remove screws in cam-switch cover. Remove cam cover.
5. Remove the four screws securing front and rear support blocks. Remove rear support block. Lift front support block and slide cam with extension shaft from front panel. Be careful not to lose the two shaft grounding springs in front support block.
6. To replace defective switch contacts, follow the instructions given in the switch repair kit.
7. To re-install switch assembly, reverse the above procedure.

**Fuse Replacements**

The fuses used in this instrument are as follows:

**TABLE 3-1  
FUSE RATINGS**

Circuit Number	Rating	Function	Location
F581	750 mA	+15 volts	Floating Board
F585	750 mA	-15 volts	Floating Board

## **Maintenance—7D12 Service**

### **Recalibration After Repair**

After any electrical component has been replaced, the calibration of that particular circuit should be checked, as well as the calibration of other closely related circuits. See Section 4, Part II-Calibration for a complete calibration procedure.

### **Instrument Repackaging**

If this instrument is to be shipped for long distances by commercial transportation, it is recommended that it be

repackaged in the original manner for maximum protection. The original shipping carton can be saved and used for this purpose. An illustration associated with the Mechanical Parts List shows how to repackage the 7D12 and gives the part number for the packaging components. New shipping cartons can be obtained from Tektronix, Inc. Contact your local Tektronix Field Office or representative.

# PERFORMANCE CHECK/CALIBRATION

## PRELIMINARY INFORMATION

### CALIBRATION INTERVAL

To ensure instrument accuracy, check the calibration of the 7D12 every 1000 hours of operation, or every six months if used infrequently. Before complete calibration, thoroughly clean and inspect this instrument as outlined in the Maintenance section.

### TEKTRONIX FIELD SERVICE

Tektronix, Inc. provides complete instrument repair and recalibration at local Field Service Centers and the Factory Service Center. Contact your local Tektronix Field Office or representative for further information.

### USING THIS PROCEDURE

#### Index

To aid in locating a step in the Performance Check or Calibration procedures, an index is given preceding Part I-Performance Check and Part II-Calibration.

#### Performance Check

The performance of this instrument can be checked, without removing the covers or making internal adjustments, by performing only Part I-Performance Check. The procedure checks all the basic functions of the 7D12 for proper operation as a single unit. Actual performance requirements are listed and checked as an integral part of the module(s) Performance Requirements and performance checks. (See module Specification section(s) in Operators manual.)

#### Calibration Procedure

Completion of each step in Part II-Calibration, ensures that this instrument is correctly adjusted and performing within all given tolerances. Where possible, instrument performance is checked before an adjustment is made. For best overall performance when performing a complete calibration, make each adjustment to the exact setting, even if the CHECK — is in tolerance.

#### Partial Procedures

A partial performance check or calibration is often desirable after relocating components, or to touch up the adjustment of a portion of the instrument between major recalibrations. To check or adjust only part of the instrument, start with the Equipment Required list preceding the desired portion of the procedure. To prevent unnecessary recalibration of other parts of the instrument, readjust only if the tolerance given in the CHECK — part of the step is not met. If readjustment is necessary, also check any steps listed in the INTERACTION — part of the step.

#### TEST EQUIPMENT REQUIRED

The test equipment and accessories listed in Table 4-1, or equivalent, is required for complete calibration of the 7D12. Specifications given for the equipment are the minimum necessary for accurate calibration. Therefore, the equipment used must meet or exceed the listed specifications. Detailed operating instructions for the test equipment are not given in this procedure. Refer to the appropriate instruction manual if more information is needed.

If only a Performance Check is to be performed, not all of the listed test equipment is required. Items used only for calibration are indicated by footnote 1. The remaining pieces of equipment are common to both procedures.

#### Special Calibration Fixtures

Special Tektronix calibration fixtures are used only where they facilitate instrument calibration. These special calibration fixtures are available from Tektronix, Inc. Order by part number through your local Tektronix Field Office or representative.

#### Calibration Equipment Alternatives

All of the listed test equipment is required to completely check and calibrate this instrument. However, complete checking or calibration may not always be necessary or desirable. The user may be satisfied with checking only selected characteristics, thereby reducing the amount of test equipment actually required.

The Performance Check and Calibration procedures are based on the first item of equipment given as an example. When other equipment is substituted, control

## Performance Check/Calibration—7D12 Service

settings or calibration setup might need to be altered. If the exact item of equipment given as an example in the Test Equipment list is not available, first check the specifications column carefully to see if any other equipment might suffice. Then check the Usage column to see what this item is used for. If used for a check or adjustment that is of little or no importance to your measurement requirements, the item and corresponding step(s) can be deleted.

The following procedure is written to completely check and adjust the 7D12 and to allow interchangeability of M-series module units without the need to completely recalibrate the instrument with each module.

### Signal Connections

Detailed signal-connection information is not given in this procedure except where critical for a particular test. In general, the external trigger input connector should be connected to other equipment with 50-ohm BNC cables. The input impedance is determined by the module used. Since the 7D12 is completely calibrated using the 7D12 Calibration Fixture, the external trigger input impedance will remain at 10K ohms throughout the procedure. Use a BNC T connector to simultaneously connect a signal to two inputs. Signal-connection and termination information for the test equipment should be available in the associated instruction manual.

**TABLE 4-1**  
**TEST EQUIPMENT**

Description	Minimum Specifications	Usage	Examples of Applicable Test Equipment
1. Indicator Oscilloscope	Tektronix 7000-series oscilloscope equipped with a readout system and a calibrator square-wave output, 0.2 V and 0.4 V into 50Ω.	Used throughout procedure to provide a display and square-wave calibrator signal.	a. Tektronix 7704A Oscilloscope System. b. Tektronix 7904 Oscilloscope System.
2. Calibration Fixture	Tektronix 7D12 Calibration Fixture	Used throughout procedure	a. Tektronix Part 067-0700-00.
3. Time-Base Unit	Tektronix 7-B series	Used throughout procedure to provide sweep.	a. Tektronix 7B53A Dual Time Base. b. Tektronix 7B92 Dual Time Base. c. Tektronix 7B70 Time Base.
4. Amplifier Plug-in Unit <sup>1</sup>	Compatible with Tektronix 7000-series oscilloscopes. Vertical sensitivity, 10 μV per division.	Column current adjustment. Gate pulse neutralization adjustment. Inverter signal neutralization adjustment.	a. Tektronix 7A22 Differential Amplifier.
5. DC Voltage Calibrator <sup>1</sup>	Range, 0 to 2V into 1 MΩ; accuracy, within 0.01%	A/D gain adjustment. Column current adjustment.	a. Fluke Model 341A or 343A DC Voltage Calibrator. b. Hewlett Packard Model 740B.

<sup>1</sup>Used for calibration only; NOT used for performance check.

TABLE 4-1 (cont)

Description	Minimum Specifications	Usage	Examples of Applicable Test Equipment
6. Medium-Frequency Constant Amplitude Signal Generator <sup>1</sup>	Frequency, 100 mHz reference frequency equal to, or less than 50 kHz; output amplitude, variable from 0.5 V to 3 V peak-to-peak into 50 $\Omega$ ; amplitude constant within 3% of reference amplitude as output frequency changes.	Vertical display frequency response check. Gate waveform frequency response check.	a. Tektronix Type 191 Constant Amplitude Signal Generator.
7. Plug-in Extender <sup>1</sup>	Tektronix 7000-series plug-in extender.	Allows access to internal adjustments in the 7D12.	a. Tektronix Part 067-0616-00 (flexible). b. Tektronix Part 067-0589-00 (rigid).
8. Precision DC Voltmeter <sup>1</sup>	Accuracy within 0.5% range, 0 to 5V; resolution, at least 5 mV.	Floating power supply; vertical display and analog-to-digital converter adjustments.	a. Tektronix 7D13 Digital Multimeter. b. Weston Model 4440 Digital Multimeter. c. Fluke Model 825A Differential DC Voltmeter.
9. Square Wave Generator <sup>1</sup>	Risetime, greater than 1 nS; output amplitude at least 500 mV into 50 $\Omega$ .	Attenuator high frequency compensation adjustment.	a. Tektronix Type 106 Square-Wave Generator.
10. 1X Voltage Probe <sup>1</sup>	Compatible with Tektronix amplifier units.	Inverter signal neutralization adjustment. Gate pulse neutralization adjustment.	a. Tektronix P6011 Probe.
11. 10X Voltage Probe <sup>1</sup> (two required).	Compatible with Tektronix amplifier units	Column current adjustment	a. Tektronix P6006 Probe.
12. Cable, Special Purpose	Connectors, pin jack to BNC male; length, 20 inches.	Calibrator pin jack signal coupling.	a. Tektronix Part 175-1178-00.
13. 50 ohm Coaxial Cable	Impedance, 50 $\Omega$ ; length, 42 inches; connectors, BNC male.	Used throughout procedure for signal coupling.	a. Tektronix Part 012-0057-01.
14. Adapter	Connectors, dual banana to female BNC	Used throughout procedure for coupling of coaxial cable to banana jacks.	a. Tektronix Part 103-0090-00.
15. Patch Cord <sup>1</sup>	Connectors, banana; length, 18 inches.	A/D bias adjustment	a. Tektronix Part 012-0031-00 (red). b. Tektronix Part 012-0039-00 (black).

TABLE 4-1 (cont)

Description	Minimum Specifications	Usage	Examples of Applicable Test Equipment
16. Screwdriver <sup>1</sup>	Three-inch shaft, 3/32-inch bit.	Used throughout procedure to adjust variable resistors.	a. Xcelite R-3323.
17. Tuning Tool <sup>1</sup>	Low Capacitance.	Used throughout procedure to adjust variable capacitors.	a. Tektronix Part 003-0675-00.



## PART 1 — PERFORMANCE CHECK

### INTRODUCTION

The following procedure checks the performance of the 7D12 as a single unit without making internal adjustment. All tolerances given in this procedure are intended to indicate proper operation only and should not be interpreted as instrument specifications.

### INDEX TO PART 1—PERFORMANCE CHECK

	Page
Preliminary Procedure for Performance Check	
Vertical Display	
1. Check Display Attenuator Readout and Gain Accuracy.	4-6
2. Check Chopped and Alternate Mode.	4-6
Voltage Readout Display and Triggering	
3. Check Auto, External and Manual Functions.	4-7
Gate Display	
4. Check Gain Accuracy and Position Control.	4-8

### PRELIMINARY PROCEDURE FOR PERFORMANCE CHECK

*NOTE*

*The performance of this instrument can be checked at any temperature within the +15° C to +40° C range unless stated otherwise.*

1. Insert the 7D12 calibration fixture into the 7D12 (see Fig. 4-1) and install them in a vertical plug-in compartment of the indicator oscilloscope.



Fig. 4-1. 7D12 Calibration Fixture installed.

2. Install a time-base unit into the horizontal compartment of the indicator oscilloscope.
3. Connect the indicator oscilloscope to a power source which meets the voltage and frequency requirements of the oscilloscope power supply.
4. Turn the indicator oscilloscope on. Allow at least 20 minutes warmup time before checking the 7D12 performance.
5. Set the indicator oscilloscope modes to display the time base and 7D12. Select the 7D12 as the internal trigger source for the time-base unit.
6. Set the indicator oscilloscope readout and intensity controls to obtain a useable readout and sweep display on the crt. The readout display (voltage readout) should appear in the upper graticule division, and the vertical display sensitivity should appear in the lower division in a location corresponding to the plug-in compartment used.

## VERTICAL DISPLAY

<p><b>Equipment Required</b></p> <p>1. Indicator oscilloscope.</p>	<p>2. 7D12 Calibration Fixture.</p> <p>3. 50 ohm coaxial cable.</p>
--	---

**1. Check Display Attenuator Readout and Gain Accuracy.**

a. Set the controls as follows:

7D12	
VERTICAL DISPLAY ATTEN	1X
TRIGGERING	AUTO
GATE	OUT—OFF

7D12 Calibration Fixture

Atten Readout Check	Out
---------------------	-----

b. CHECK — Rotate the VERTICAL DISPLAY POSITION control fully clockwise and counterclockwise. The trace should move off the graticule area in both directions.

c. Position the trace 2 divisions below the center graticule line.

d. Connect a 400 millivolt, 1 kilohertz signal from the oscilloscope calibrator to the 7D12 Calibration Fixture Vertical Display Direct Input Connector.

e. CHECK — Set the VERTICAL DISPLAY ATTEN switch to the settings given in Table 4-2. The display amplitude and lower numerical readout display should be within the limits for each switch setting listed in Table 4-2.

f. Disconnect the calibrator signal.

**2. Check Chopped and Alternate Mode.**

a. Remove the 7D12 from the indicator oscilloscope.

b. Remove the 7D12 left side panel and set the internal Display Mode switch to the Alt position. See Fig. 1-3.

c. Insert the 7D12 into the oscilloscope vertical plug-in compartment.

d. Set the 7D12 GATE switch to ON.

e. Set the time base unit sweep rate to 50 milliseconds per division.

f. CHECK — The Vertical Display trace and the Gate trace should be displayed alternately with each sweep on the crt.

g. Set the 7D12 internal Display Mode switch to the Chop position, and replace the left side panel. Refer to Fig. 1-3.

h. CHECK — The Vertical Display trace and the Gate trace should start at the same time.

**TABLE 4-2  
VERTICAL DISPLAY AMPLITUDE  
AND LOWER NUMERICAL READOUT**

7D12 VERTICAL DISPLAY ATTEN Switch	Display Amplitude (divisions)		Lower Numerical Readout Display
	Min.	Max.	
1X	4.4	4.8	1
2X	2.2	2.4	2
5X	0.87	0.97	5

## VOLTAGE READOUT DISPLAY AND TRIGGERING

**Equipment Required**

- |  |   |
|--|---|
| <ol style="list-style-type: none"> <li>1. Indicator oscilloscope.</li> <li>2. 7D12 Calibration Fixture.</li> </ol> | <ol style="list-style-type: none"> <li>3. 50 ohm coaxial cable.</li> <li>4. Special purpose cable.</li> <li>5. Dual-banana-plug to female BNC adapter.</li> </ol> |
|--|---|

**3. Check Auto, External, and Manual Functions.**

a. CHECK — The AUTO, EXT and MAN TRIGGERING buttons light when pushed.

b. Set the controls as follows:

	7D12	
TRIGGERING		AUTO
GATE		OUT—OFF
	7D12 Calibration Fixture	
Atten Readout Check		Out

Controls not mentioned can be set as desired.

c. CHECK — The TRIG'D indicator light is flashing and the voltage readout display reads approximately zero volts.

d. Connect a 4 volt, 1 kilohertz signal from the oscilloscope calibrator to the 7D12 Calibration-Fixture A/D Direct Input jacks.

e. CHECK — The voltage readout display should read approximately 2 volts (depending upon the accuracy of the oscilloscope calibrator).

f. Set the 7D12 TRIGGERING switch to EXT.

g. CHECK — The TRIG'D indicator light should not be on.

h. Disconnect the calibrator signal.

i. CHECK — The voltage readout obtained in part e should remain displayed on the crt.

j. Connect a 4 volt, 1 kilohertz signal from the oscillator calibrator to the TRIGGERING EXT IN connector.

k. CHECK — The voltage readout display reads zero volts and the TRIG'D indicator light is lit.

l. Disconnect the calibrator signal from the TRIGGERING EXT IN connector and connect it to the 7D12 Calibration Fixture, A/D Direct Input jacks.

m. Push the MAN TRIGGERING button.

n. CHECK — The voltage readout display should read approximately +2 volts.

o. Reverse the polarity to the 7D12 Calibration Fixture, A/D Direct Input jacks.

p. Push the MAN TRIGGERING button.

q. CHECK — The voltage readout display should read approximately —2 volts.

r. Disconnect all connections.

## GATE DISPLAY

### Equipment Required

- |                              |                           |
|------------------------------|---------------------------|
| 1. Indicator oscilloscope.   | 3. 50 ohm coaxial cable.  |
| 2. 7D12 Calibration fixture. | 4. Special purpose cable. |

#### 4. Check Gain Accuracy and Position Control.

- a. Set the controls as follows:

GATE	7D12	ON
------	------	----

Any controls not mentioned can be set as desired.

- b. Set the time-base unit sweep rate to 100 microseconds per division.
- c. CHECK — Rotate the GATE POSITION control fully clockwise and counterclockwise. The gate trace should move off the graticule area in both directions.

- d. Set the gate trace 1 division below the center horizontal graticule line.

- e. Connect a 200 millivolt signal from the oscillator calibrator to the 7D12 Calibration Fixture, Gate Waveform Direct Input connector.

- f. CHECK — The gate waveform amplitude to be from 1.5 to 2.5 divisions.

- g. Disconnect the coaxial cable.

This completes the Performance Check of the 7D12.

## PART II — CALIBRATION PROCEDURE

7D12, Serial No. \_\_\_\_\_ Page  
 Calibration Date \_\_\_\_\_  
 Calibrated by \_\_\_\_\_

## INTRODUCTION

The following procedure returns the 7D12 to correct calibration. All limits and tolerances given in this procedure are calibration guides, and should not be interpreted as instrument specifications except as listed as a Performance Requirement in the Operators manual.

## Analog to Digital Converter

- |  |      |
|--|------|
| 12. Adjust auto Triggering Measurement Rate.               | 4-16 |
| 13. Check Manual and External Triggering Measurement Rate. | 4-16 |
| 14. Adjust A/D Bias.                                       | 4-17 |
| 15. Adjust Column Current.                                 | 4-17 |
| 16. Adjust A/D Gain.                                       | 4-18 |
| 17. Adjust Gain Pulse Neutralization.                      | 4-18 |

## INDEX TO CALIBRATION PROCEDURE

	Page
Preliminary Procedure for Calibration	4-9

## FLOATING POWER SUPPLY

- |  |      |
|--|------|
| 1. Adjust +5 Volt Supply.                    | 4-10 |
| 2. Check all Floating Power Supply Voltages. | 4-10 |
| 3. Adjust Inverter Signal Neutralization.    | 4-10 |

## VERTICAL DISPLAY

- |                                   |      |
|-----------------------------------|------|
| 4. Adjust Trigger Level.          | 4-12 |
| 5. Adjust Attenuator Balance.     | 4-12 |
| 6. Adjust Amplifier Gain.         | 4-12 |
| 7. Check Attenuator and Readout.  | 4-12 |
| 8. Check Chop and Alternate Mode. | 4-13 |

## BANDWIDTH

- |   |      |
|---|------|
| 9. Adjust Attenuator High Frequency Compensation. | 4-14 |
| 10. Check Vertical Display Frequency Response.    | 4-14 |
| 11. Check Gate Waveform Frequency Response.       | 4-15 |

## PRELIMINARY PROCEDURE FOR CALIBRATION

## NOTE

*This instrument should be calibrated at an ambient temperature of +25°C for best overall accuracy.*

1. Remove both side panels from the indicator oscilloscope.
2. Remove the side covers from the 7D12.
3. Insert the 7D12 calibration fixture module into the 7D12. Refer to Fig. 4-1.
4. Connect a plug-in extender from the vertical plug-in compartment of the indicator oscilloscope to the 7D12.
5. Install a time-base unit in the horizontal compartment of the indicator oscilloscope.
6. Connect the indicator oscilloscope to a power source which meets the voltage and frequency requirements of the oscilloscope power supply.
7. Turn the indicator oscilloscope on. Allow at least 20 minutes warmup before proceeding with the first section.

## NOTE

*Titles for external controls of this instrument are capitalized in this procedure (e.g., POSITION). Internal adjustments are initial capitalized only (e.g., Display Gain).*

## FLOATING POWER SUPPLY

### Equipment Required

- |                              |                      |
|------------------------------|----------------------|
| 1. Indicator oscilloscope.   | 5. Plug-in extender. |
| 2. 7D12 Calibration Fixture. | 6. 1X voltage probe. |
| 3. Precision dc voltmeter.   | 7. Screwdriver.      |
| 4. Amplifier plug-in unit.   | 8. Tuning tool.      |

BEFORE YOU BEGIN, see **ADJUSTMENT LOCATIONS** in the diagrams section.

### CONTROL SETTINGS

Set the controls as follows:

7D12	
VERTICAL DISPLAY POSITION	midrange
GATE	OUT-OFF

Controls not mentioned can be set as desired.

#### 1. Adjust +5 volt supply.

- a. Connect the precision dc voltmeter between the 5V TP and F GND (floating ground) test points.
- b. CHECK — Meter reading; +5.00 volts  $\pm$ 0.01 volt.
- c. ADJUST — +5 Volts adjustment R613 for a meter reading of +5.00 volts.
- d. INTERACTION — Any change in the setting of R613 may affect A/D Gain. Check step 30.

#### 2. Check all Floating Power-Supply Voltages.

- a. CHECK — Table 4-3 lists the floating power supply voltages in the instrument. Check each supply with the precision dc voltmeter for output voltage within the given limits.

- b. Disconnect the voltmeter.

#### 3. Adjust Inverter Signal Neutralization.

- a. Install an amplifier plug-in unit (Tektronix 7A22) into the vacant vertical compartment of the indicator oscilloscope.
- b. Connect a 1X voltage probe from the amplifier plug-in unit input connector to the F GND (floating ground) test point. (Connect the probe ground strap to chassis ground.)

TABLE 4-3  
FLOATING POWER SUPPLY LIMITS

Floating Power Supply	Output Voltage Limits (volts)		Test Point Location (refer to Adjustment Locator)
	Min.	Max.	
+5 volt	+4.87	+5.13	H
-15 Volt	-14.62	-15.38	G
+15 Volt	+14.62	+15.38	L

**Performance Check/Calibration—7D12 Service**

c. Set the controls as follows:

	7D12	
TRIGGERING	7D12 Calibration Fixture	EXT
Atten Readout Check	7A22	Out
Volts/div.		10 MV
HF-3 dB Point		1 MHz
LF-3 dB Point		10 KHz
+ coupling		ac
— coupling		Gnd

Controls not mentioned can be set as desired.

d. Set the time-base unit for a sweep rate of 20 microseconds per division.

e. CHECK — That the inverter pulse is neutralized (chopped signal null). Refer to example in Fig. 4-2b.

f. ADJUST — The Inverter Sig Neut adjustment, C593 to neutralize (null) the inverter pulse shown in Fig. 4-2a.

*NOTE*

*The transformer (T595) leads can be dressed to optimize the C593 adjustment if necessary.*

g. Disconnect the 1X voltage probe and remove the amplifier plug-in unit from the indicator oscilloscope.

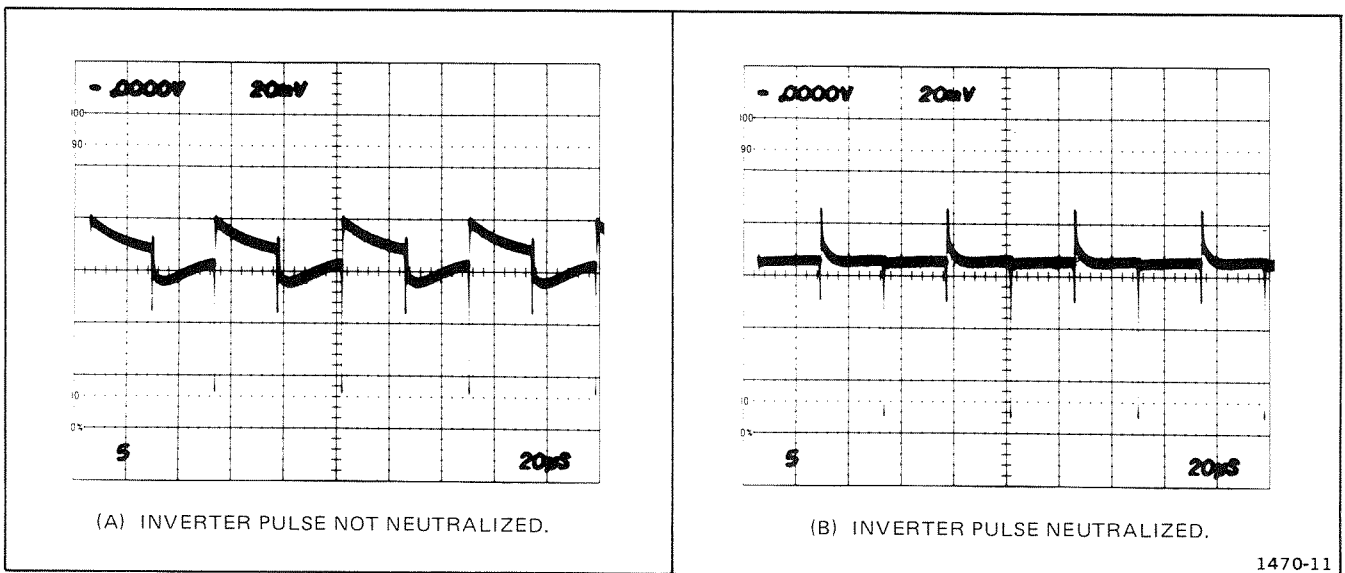

Fig. 4-2. Typical Inverter pulse waveform properly neutralized.

## VERTICAL DISPLAY

Equipment Required	
1. Indicator oscilloscope.	4. Time-base unit.
2. 7D12 Calibration Fixture.	5. Precision dc voltmeter.
3. Plug-in extender.	6. 50 ohm coaxial cable.
	7. Screwdriver.

*BEFORE YOU BEGIN, see **ADJUSTMENT LOCATIONS** in the diagrams section.*

### CONTROL SETTINGS

Set the controls as follows:

	7D12	
GATE		OUT-OFF

Controls not mentioned can be set as desired.

#### 4. Adjust Trigger Level.

- a. Position the trace to the horizontal center line of the graticule using the VERTICAL DISPLAY POSITION control.
- b. Connect the precision dc voltmeter between TP 177 and chassis ground.
- c. CHECK — Meter reading; 0.000 volt  $\pm$  0.020 volt.
- d. ADJUST — Trig Level adjustment R169 for a meter reading of 0.000 volt.
- e. Disconnect the voltmeter.

#### 5. Adjust Attenuator Balance.

- a. Set the VERTICAL DISPLAY ATTEN switch to 5X.
- b. Position the trace to the horizontal center line of the graticule using the VERTICAL DISPLAY POSITION control.
- c. Set the VERTICAL DISPLAY ATTEN switch to 1X.

d. CHECK — For no vertical trace shift.

e. ADJUST — Display Offset adjustment R138 to return the trace to the horizontal center line of the graticule.

f. INTERACTION — Repeat parts a through e several times to minimize vertical trace shift.

g. CHECK — Rotate the VERTICAL DISPLAY POSITION control fully clockwise and counterclockwise. The trace should move off the graticule area in both directions.

#### 6. Adjust Amplifier Gain.

a. Set the controls as follows:

	7D12	
VERTICAL DISPLAY ATTEN		1X
7D12 Calibration Fixture		
Attenuator Readout Check		Out

b. Connect a 400 millivolt, 1 kilohertz signal from the oscilloscope calibrator to the 7D12 Calibration Fixture Vertical Display Direct Input Connector.

c. CHECK — The display amplitude should be within the limits of 4.4 to 4.8 divisions.

d. ADJUST — Display Gain adjustment R195, for exactly 4.6 divisions in amplitude.

#### 7. Check Attenuation and Readout.

a. CHECK — Set the VERTICAL DISPLAY ATTEN switch to the settings given in Table 4-4. The display



**Performance Check/Calibration—7D12 Service**

amplitude and lower numerical readout should be within the limits for each switch setting listed in Table 4-4.

b. Disconnect the oscilloscope calibrator signal.

**8. Check Chop and Alternate Mode.**

- a. Set the GATE switch to ON.
- b. Set the internal Display Mode switch to Alt. (See Fig. 1-3 in the Operating Information section.)
- c. Adjust the VERTICAL DISPLAY POSITION and the GATE POSITION controls to separate the two traces approximately 4 division.

d. Set the time-base sweep rate to 50 milliseconds per division.

e. CHECK — The vertical display trace and the gate trace should be displayed alternately with each sweep on the crt.

f. Set the internal Display Mode switch to the Chop position.

g. CHECK — The vertical display trace and the gate trace should start at the same time.

h. Set the time-base unit sweep rate to 50 microseconds per division.

i. CHECK — Rotate the GATE POSITION control fully clockwise and counterclockwise. The trace should move off the graticule area in both directions.

**TABLE 4-4  
VERTICAL DISPLAY AMPLITUDE  
AND LOWER NUMERICAL READOUT**

7D12 VERTICAL DISPLAY ATTEN Switch	Display Amplitude (divisions)		Lower Numerical Readout Display
	Min.	Max.	
1X	adjusted	1	
2X	2.2	2.4	2
5X	0.87	0.97	5

## BANDWIDTH

### Equipment Required

- |   |   |
|---|---|
| <ol style="list-style-type: none"> <li>1. Indicator oscilloscope.</li> <li>2. 7D12 Calibration Fixture.</li> <li>3. Square wave generator.</li> </ol> | <ol style="list-style-type: none"> <li>4. Time-base unit.</li> <li>5. Medium-frequency generator.</li> <li>6. Tuning tool.</li> <li>7. 50 ohm coaxial cable.</li> </ol> |
|---|---|

BEFORE YOU BEGIN, see

### ADJUSTMENT LOCATIONS

in the diagrams section.

### CONTROL SETTINGS

Set the controls as follows:

7D12	
VERTICAL DISPLAY ATTEN	1X
GATE	OUT-OFF

Controls not mentioned can be set as desired.

#### 9. Adjust Attenuator High Frequency Compensation.

- a. Disconnect the plug-in extender. Install the 7D12 directly into the indicator oscilloscope vertical plug-in compartment.
- b. Connect a 100 kilohertz fast-rise signal from the square-wave generator to the 7D12 Calibration Fixture Vertical Display Direct Input connector.
- c. Set the time-base unit to obtain a triggered display at a sweep rate of 10 nonoseconds per division.
- d. Adjust the square-wave generator controls to display 5 divisions of amplitude on the crt.
- e. Position the top of the square wave to the horizontal center line of the graticule.
- f. CHECK — Abberations should not exceed  $\pm 0.25$  division.
- g. ADJUST — 1X HF Comp, and Display HF Comp adjustments, C102 and C198, alternately for best front corner and flat top.
- h. Set the VERTICAL DISPLAY ATTEN switch to 2X.
- i. Adjust the square-wave generator controls to display 2.8 divisions of signal amplitude on the crt.

j. Position the top of the square wave to the horizontal center line of the graticule.

k. CHECK — Abberations should not exceed  $\pm 0.14$  division.

l. ADJUST — 2X HF Comp adjustment C106 for best front corner and aberrations within  $\pm 0.14$  division.

m. Set the VERTICAL DISPLAY ATTEN switch to 5X.

n. Adjust the square-wave generator controls to display 1.1 divisions of amplitude on the crt.

o. Position the top of the square wave to the horizontal center line of the graticule.

p. CHECK — Abberations should not exceed  $\pm 0.006$  division.

q. ADJUST — 5X HF Comp adjustment C110 for best front corner and aberrations within  $\pm 0.06$  division.

r. Disconnect the square-wave signal.

#### 10. Check Vertical Display Frequency Response.

- a. Set the VERTICAL DISPLAY ATTEN switch to 1X.
- b. Set the time-base unit for a sweep rate of 500 microseconds per division.
- c. Connect the medium-frequency generator output to the 7D12 Calibration Fixture Vertical Display Direct Input connector.
- d. Set the medium-frequency generator for 6 divisions of vertical deflection at its reference frequency (50 kilohertz).

## Performance Check/Calibration—7D12 Service

e. Without changing the output amplitude, increase the output frequency of the generator to 100 megahertz.

f. CHECK — crt display for 4.2 divisions or more vertical deflection.

g. Set the VERTICAL DISPLAY ATTEN switch to 2X.

h. Repeat parts d through f.

i. Set the VERTICAL DISPLAY ATTEN switch to 5X.

j. Repeat parts d through f.

k. Disconnect the medium-frequency generator.

### 11. Check Gate Waveform Frequency Response.

a. Position the vertical display trace off the graticule area.

b. Set the GATE switch to ON.

c. Connect the medium-frequency generator output to the 7D12 Calibration Fixture Gate Waveform Direct Input connector.

d. Set the medium frequency generator for 6 divisions of vertical deflection at its reference frequency (50 kilohertz).

e. Without changing the output amplitude, increase the output frequency of the generator to 100 megahertz.

f. CHECK — crt display for 4.2 divisions or more vertical deflection.

g. Disconnect the medium-frequency generator.

## ANALOG TO DIGITAL CONVERTER

### Equipment Required

1. Indicator oscilloscope.
2. 7D12 Calibration Fixture
3. Time-Base unit.
4. Plug-in extender.
5. DC Voltage calibrator.
6. Precision dc voltmeter.
7. Amplifier plug-in unit.
8. Special purpose cable.
9. Patch Cord.
10. 10X probe (two required).
11. 1X probe.
12. 50 ohm coaxial cable.
13. Dual-banana-plug to female BNC adapter.
14. Screwdriver.
15. Tuning tool.

BEFORE YOU BEGIN, see **ADJUSTMENT LOCATIONS** in the diagrams section.

### 12. Adjust Auto Triggering Measurement Rate.

- a. Connect a plug-in extender between the 7D12 and indicator oscilloscope.
- b. CHECK — The AUTO EXT and MAN TRIGGERING buttons light when pushed.
- c. Set the 7D12 TRIGGERING switch to AUTO.
- d. Connect a 4 volt, 1 kilohertz signal from the oscilloscope calibrator to the 7D12 Calibration Fixture, A/D Direct Input jacks.
- e. CHECK — The TRIG'D indicator light is flashing and the crt readout display is updating about four times per second.
- f. ADJUST — Trig Rate adjustment, R441 to the desired measurement rate. See the following note.

#### NOTE

*The measurement rate can be adjusted from one to approximately four measurements per second determined by the setting of Trig Rate adjustment R441. This is factory preset to approximately four measurements per second. The Trig Rate range can be adjusted to 12 measurements per second by changing the value of R407 to 30 K $\Omega$ .*

### 13. Check Manual and External Triggering Measurement Rate.

- a. CHECK — The voltage readout display should read approximately 2 volts (depending upon the accuracy of the oscilloscope calibrator).
- b. Set the TRIGGERING switch to EXT.
- c. CHECK — The TRIG'D indicator light should not be on.
- d. Disconnect the calibrator signal.
- e. CHECK — The voltage readout obtained in part a should remain displayed on the crt.
- f. Connect a 4 volt, 1 kilohertz signal from the oscilloscope calibrator to the TRIGGERING EXT IN connector.
- g. CHECK — The voltage readout display reads 0 volts and the TRIG'D indicator light is lit.
- h. Disconnect the calibrator signal.
- i. Connect a 4 volt, 1 kilohertz signal from the oscilloscope calibrator to the 7D12 Calibration Fixture, A/D Direct Input jacks.
- j. Push the MAN TRIGGERING button.

- k. CHECK — The voltage readout display should read approximately +2 volts.
- l. Reverse the polarity to the Calibration Fixture, A/D Direct Input Jacks.
- m. Push the MAN TRIGGERING button.
- n. CHECK — The voltage readout display should read approximately -2 volts.
- o. Disconnect all connections.

**14. Adjust A/D Bias.**

- a. Short the 7D12 Calibration Fixture, A/D Direct Input jacks with a patch cord.
- b. Connect a precision dc voltmeter plus and minus leads between TP 244 and F GND (floating ground) respectively.
- c. CHECK — Meter reading; +0.195 volt  $\pm$ 0.010 volt.
- d. ADJUST — FET Bias adjustment R249 for a meter reading of +0.195 volt.
- e. Disconnect all connections.

**15. Adjust Column Current.**

- a. Install an amplifier plug-in unit into the vacant vertical compartment of the indicator oscilloscope.

- b. Connect a 10X probe from the amplifier plug-in unit input to the indicator oscilloscope column data switch IC (integrated circuit) pin 7, located on the oscilloscope readout circuit board.
- c. Connect a 10X probe from the time-base unit external trigger input to the indicator oscilloscope row data switch IC (integrated circuit) pin 3, located on the oscilloscope readout circuit board.
- d. Connect a dc voltage calibrator output to the 7D12 Calibration Fixture A/D Direct Input jacks.
- e. Set the controls as follows:

7D12  
TRIGGERING AUTO  
7D12 Calibration Fixture  
Readout Calibration In

- f. Controls not mentioned can be set as desired.
- f. Set the time-base unit controls to trigger on the negative slope of the external trigger signal.
- g. Set the amplifier plug-in unit controls to display a signal amplitude (dc coupled) of 4.5 divisions. See Fig. 4-3a.
- h. Adjust the dc voltage calibrator voltage slowly between zero and two volts. Push the EXT TRIGGERING button the instant any numeral 8 appears in the readout display (refer to Fig. 4-3a). It may be necessary to repeat this step several times in order to hold the display on a 8 readout.

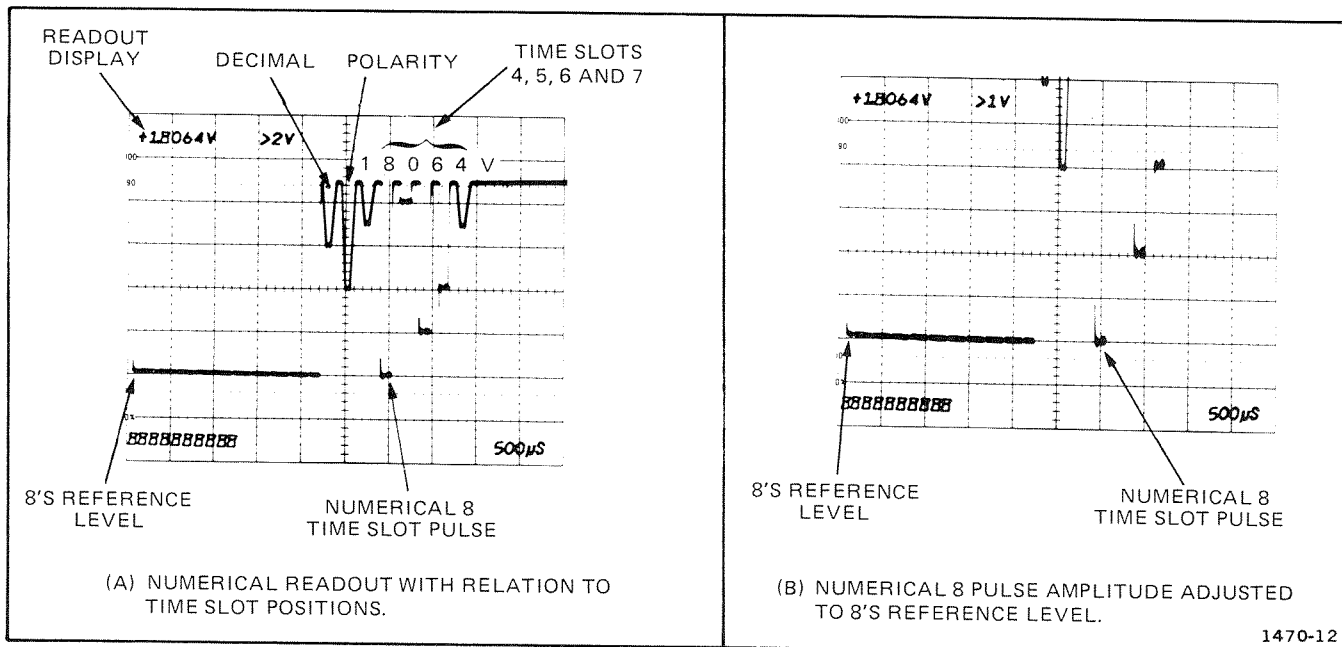

Fig. 4-3. Typical time-slot pulses with relation to the readout display.

## Performance Check/Calibration—7D12 Service

### NOTE

The example in Fig. 4-3a shows the numeral 8 located in time slot four, and the pulse amplitude approximately equal to the 8's reference level (8's pulses amplitude standard).

- i. Set the amplifier plug-in unit controls to display a signal amplitude of approximately 9 divisions (upper half of display off graticule area).
- j. Position the 8's reference level to a horizontal graticule line. See Fig. 4-3b.
- k. CHECK — The numeral 8 time-slot pulse amplitude should be equal to the 8's reference level.
- l. ADJUST — Column Current adjustment, R499 to position the numeral 8 time slot pulse amplitude to the 8's reference level. See example in Fig. 4-3b.
- m. Set the TRIGGERING switch to AUTO.
- n. CHECK — Adjust the dc voltage calibrator output amplitude slowly from 0 through 2 volts. The tens readout (first digit right of decimal) should be able to display all numerals, from 0 through 9. See note below.

### NOTE

If all numerals can be displayed in the tens readout, disregard the following portions this check. However, if any numeral from 0 through 7 is omitted repeat parts h, o, p and s; if the numeral 8 or 9 is omitted, repeat parts, h, q, r and s.

- o. ADJUST — Column Current adjustment, R499, to position the numeral 8 time slot pulse amplitude down to the numeral 7 level (the digital readout display 8 will change to 7).
- p. Repeat parts m and n. If all numerals are displayed in the tens readout, repeat parts h through n.
- q. ADJUST — Column Current adjustment, R499, to position the numeral 8 time slot pulse amplitude up to the numeral 9 level (the digital readout display 8 will change to 9).
- r. Repeat parts m and n. If all numerals are displayed in the tens readout, repeat parts h through n.
- s. Disconnect all connections.

## 16. Adjust A/D Gain.

- a. Set the TRIGGERING switch to AUTO.
- b. Connect +2.0000 volts from the dc voltage calibrator output to the 7D12 Calibration Fixture, A/D Direct Input connector.
- c. CHECK — The readout display should read >2.0000V within the limits of +1.9966V to >2.0034V.
- d. ADJUST — A/D Gain adjustment, R361 for a readout display of >2.0000V. See note below.

### NOTE

It may be necessary to add or remove shunt straps across R359 and R360 in order to perform part d.

- e. Disconnect all connections.

## 17. Adjust Gate Pulse Neutralization.

- a. Install an amplifier plug-in unit (Tektronix 7A22) into the vertical compartment of the indicator oscilloscope.
- b. Set the controls as follows:

	7D12	
TRIGGERING		EXT
	7D12 Calibration Fixture	
Atten Readout Check		Out
	7A22	
Volts/div		10 $\mu$ V
HF —3dB Point		3 KHz
LF —3dB Point		dc
+ coupling		ac
—coupling		gnd

Controls not mentioned can be set as desired.

- c. Connect a 1X voltage probe from the amplifier plug-in unit plus (+) input connector to the V HI test point. (Connect the probe ground strap to the F GND test point.)
- d. Connect a cable from the indicator oscilloscope gate output connector to the TRIGGERING input connector.
- e. Set the indicator oscilloscope and time-base controls for a stable amplifier plug-in unit display.

f. CHECK — For the absence of the gate pulse. See Fig. 4-4b.

g. ADJUST — The gate HF Comp adjustment C235 to neutralize the gate pulse. The gate pulse is shown in Fig. 4-4a.

h. Disconnect all connections.

This completes the Calibration Procedure for the 7D12. Disconnect all test equipment and replace the oscilloscope side panels and the 7D12 side covers.

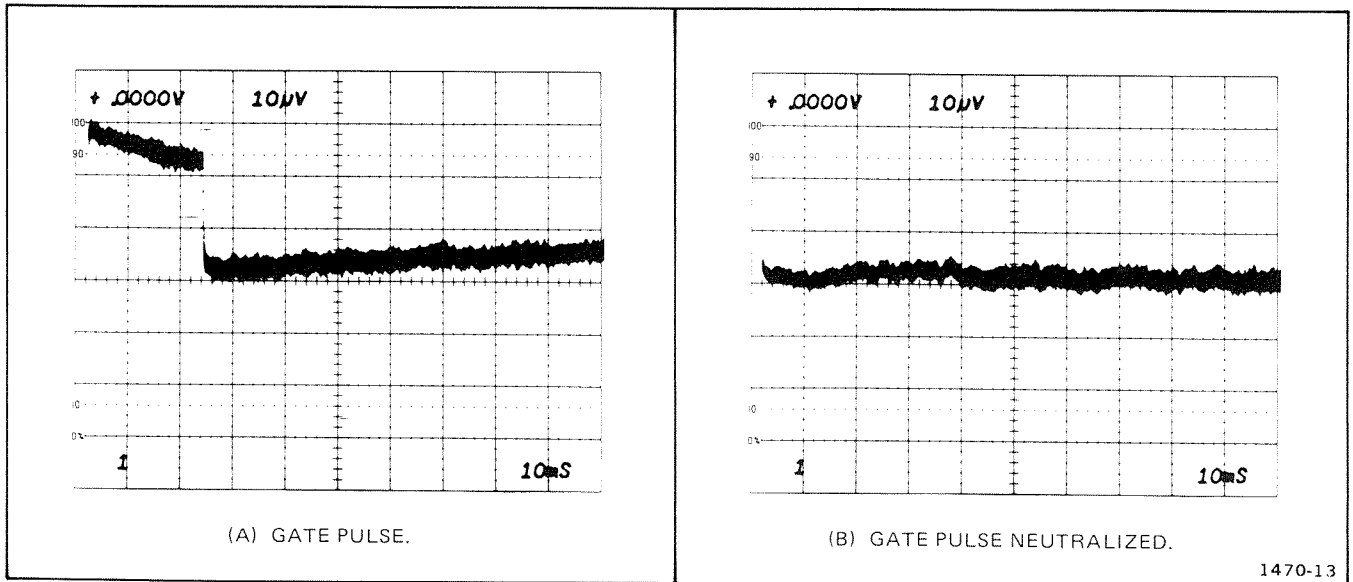

Fig. 4-4. Typical example of gate pulse neutralization.





# ELECTRICAL REPLACEABLE PARTS LIST

## PARTS ORDERING INFORMATION

Replacement parts are available from or through your local Tektronix, Inc. Field Office or representative.

Changes to Tektronix instruments are sometimes made to accommodate improved components as they become available, and to give you the benefit of the latest circuit improvements developed in our engineering department. It is therefore important, when ordering parts, to include the following information in your order: Part number, instrument type or number, serial number, and modification number if applicable.

If a part you have ordered has been replaced with a new or improved part, your local Tektronix, Inc. Field Office or representative will contact you concerning any change in part number.

Change information, if any, is located at the rear of this manual.

## SPECIAL NOTES AND SYMBOLS

- X000 Part first added at this serial number  
00X Part removed after this serial number

## ITEM NAME

In the Parts List, an Item Name is separated from the description by a colon (:). Because of space limitations, an Item Name may sometimes appear as incomplete. For further Item Name identification, the U.S. Federal Cataloging Handbook H6-1 can be utilized where possible.

## ABBREVIATIONS

ACTR	ACTUATOR	PLSTC	PLASTIC
ASSY	ASSEMBLY	QTZ	QUARTZ
CAP	CAPACITOR	RECP	RECEPTACLE
CER	CERAMIC	RES	RESISTOR
CKT	CIRCUIT	RF	RADIO FREQUENCY
COMP	COMPOSITION	SEL	SELECTED
CONN	CONNECTOR	SEMICOND	SEMICONDUCTOR
ELCTLT	ELECTROLYTIC	SENS	SENSITIVE
ELEC	ELECTRICAL	SEP	SEPARATELY
FXD	FIXED	VAR	VARIABLE
INCAND	INCANDESCENT	WW	WIREWOUND
LED	LIGHT EMITTING DIODE	XFMR	TRANSFORMER
NONWIR	NON WIREWOUND	XTAL	CRYSTAL

# CROSS INDEX MFR. CODE NUMBER TO MANUFACTURER

MFR.CODE	MANUFACTURER	ADDRESS	CITY,STATE,ZIP
01121	Allen-Bradley Co.	1201 2nd St.	Milwaukee, WI 53212
01295	Texas Instruments, Inc., Components Group	P. O. Box 5012	Dallas, TX 75222
01884	Dearborn Electronics, Inc.	P. O. Box 530	Orlando, FL 32802
02735	RCA Corp., Solid State Division	Route 202	Somerville, NY 08876
03508	General Electric Co., Semi-Conductor Products Dept., Electronics Park		Syracuse, NY 13201
04713	Motorola, Inc., Semiconductor Products Div.	5005 E. McDowell Rd.	Phoenix, AZ 85008
07263	Fairchild Semiconductor, A Div. of Fairchild Camera and Instrument Corp.	464 Ellis St.	Mountain View, CA 94040
07910	Teledyne Semiconductor	12515 Chadron Ave.	Hawthorne, CA 90250
12040	National Semiconductor Corp.	Commerce Drive	Danbury, CT 06810
12697	Clarostat Mfg. Co., Inc.	Lower Washington St.	Dover, NH 03820
15818	Teledyne Semiconductor	1300 Terra Bella Ave.	Mountain View, CA 94040
17856	Siliconix, Inc.	2201 Laurelwood Rd.	Santa Clara, CA 95050
18324	Signetics Corp.	811 E. Argues	Sunnyvale, CA 94086
18612	Vishay Resistor Products Div. Vishay Intertechnology Inc.	68 Lincoln Hwy	Malvern, PA 19355
19701	Electra/Midland Corp., A North American Phillips Co.	P. O. Box 760	Mineral Wells, TX 76067
24931	Specialty Connector Co., Inc.	3560 Madison Ave.	Indianapolis, IN 46227
26483	Monsanto Co., Electronics Test and Measurement Department	620 Passaic Ave.	West Caldwell, NJ 07006
27014	National Semi-Conductor Corp.	2950 San Ysidro Way	Santa Clara, CA 95051
56289	Sprague Electric Co.	644 W. 12th St.	North Adams, MA 01247
72982	Erie Technological Products, Inc.	2500 Harbor Blvd.	Erie, PA 16512
73138	Beckman Instruments, Inc., Helipot Div.		Fullerton, CA 92634
75042	TRW Electronic Components, IRC Philadelphia Div.	401 N. Broad St.	Philadelphia, PA 19108
75915	Littelfuse, Inc.	800 E. Northwest Hwy	Des Plaines, IL 60016
76493	Miller, J. W., Co	P. O. Box 5825	Compton, CA 90224
80009	Tektronix, Inc.	P. O. Box 500	Beaverton, OR 97005
80294	Bourns, Inc.	1200 Columbia Ave.	Riverside, CA 92507
81483	International Rectifier Corp.	9220 Sunset Blvd.	Los Angeles, CA 90069
90201	Mallory Capacitor Co.	3029 E. Washington St.	Indianapolis, IN 46206
91418	Radio Materials Co.	4242 W. Bryn Mawr	Chicago, IL 60646
91637	Dale Electronics, Inc.	P. O. Box 609	Columbus, NB 68601

Ckt No.	Tektronix Part No.	Serial/Model No.		Name & Description	Mfr Code	Mfr Part Number
		Eff	Dscont			
A1	670-2174-00	B010100	B019999	CKT BOARD ASSY:--MAIN	80009	670-2174-00
A1	670-2174-01	B020000	B039999	CKT BOARD ASSY:--MAIN	80009	670-2174-01
A1	670-2174-03	B040000		CKT BOARD ASSY:--MAIN	80009	670-2174-03
A2	670-2176-00			CKT BOARD ASSY:--FLOATING	80009	670-2176-00
A3	670-2175-00			CKT BOARD ASSY:--TRIG MODE SWITCH	80009	670-2175-00
C102	281-0184-00			CAP.,VAR,PLSTC:2-18PF,500VDC	34553	2222-809-05003
C103	281-0592-00			CAP.,FXD,CER DI:4.7PF,+/-0.5PF,500V	72982	301-023C0H0479D
C106	281-0064-00			CAP.,VAR,PLSTC:0.25-1.5PF,600V	72982	530-002
C107	281-0619-00			CAP.,FXD,CER DI:1.2PF,+/-0.1PF,200V	72982	374-000C0K0129B
C110	281-0064-00			CAP.,VAR,PLSTC:0.25-1.5PF,600V	72982	530-002
C112	281-0659-00			CAP.,FXD,CER DI:4.3PF,+/-0.25PF,500V	72982	301-000C0H0439C
C123	283-0017-00			CAP.,FXD,CER DI:1UF,+80-20%,3V	91418	MX105Z0304R0
C125	283-0081-00			CAP.,FXD,CER DI:0.1UF,+80-20%,25V	56289	36C600
C128	281-0618-00			CAP.,FXD,CER DI:4.7PF,+/-0.5PF,200V	72982	374-001C0H0479D
C134	283-0017-00			CAP.,FXD,CER DI:1UF,+80-20%,3V	91418	MX105Z0304R0
C136	283-0081-00			CAP.,FXD,CER DI:0.1UF,+80-20%,25V	56289	36C600
C148	283-0177-00			CAP.,FXD,CER DI:1UF,+80-20%,25V	72982	8131N039651105Z
C152	281-0612-00			CAP.,FXD,CER DI:5.6PF,+/-0.5PF,500V	72982	374-001C0H0569D
C158	281-0670-00			CAP.,FXD,CER DI:1.8PF,+/-0.1PF,500V	72982	374-005C0K0189B
C159	281-0645-00			CAP.,FXD,CER DI:8.2PF,+/-0.25PF,500V	72982	374-011C0H0829C
C177	281-0550-00			CAP.,FXD,CER DI:120PF,10%,500V	72982	301-000X5P0121K
C196	281-0564-00			CAP.,FXD,CER DI:24PF,5%,500V	72982	301-000C0G0240J
C197	281-0540-00			CAP.,FXD,CER DI:51PF,5%,500V	72982	301-000U2J0510J
C198	281-0184-00			CAP.,VAR,PLSTC:2-18PF,500VDC	34553	2222-809-05003
C203	281-0605-00			CAP.,FXD,CER DI:200PF,10%,500V	72982	301-000Y5D0201K
C213	281-0605-00			CAP.,FXD,CER DI:200PF,10%,500V	72982	301-000Y5D0201K
C235	281-0064-00			CAP.,VAR,PLSTC:0.25-1.5PF,600V	72982	530-002
C236	283-0167-00			CAP.,FXD,CER DI:0.1UF,10%,100V	72982	8131N147W5R104K
C240	283-0003-00			CAP.,FXD,CER DI:0.01UF,+80-20%,150V	72982	855-547E103Z
C245	290-0535-00			CAP.,FXD,ELCTLT:33UF,20%,10V	56289	196D336X0010KAL
C250	283-0111-00			CAP.,FXD,CER DI:0.1UF,20%,50V	72982	8131N075651104M
C264	283-0111-00			CAP.,FXD,CER DI:0.1UF,20%,50V	72982	8131N075651104M
C269	283-0078-00			CAP.,FXD,CER DI:0.001UF,20%,500V	56289	20C114A8
C272	283-0111-00			CAP.,FXD,CER DI:0.1UF,20%,50V	72982	8131N075651104M
C274	281-0512-00			CAP.,FXD,CER DI:27PF,+/-2.7PF,500V	72982	308-000C0G0270K
C290	281-0580-00			CAP.,FXD,CER DI:470PF,10%,500V	72982	301-000Z5D0471K
C294	281-0580-00			CAP.,FXD,CER DI:470PF,10%,500V	72982	301-000Z5D0471K
C302	285-0809-00			CAP.,FXD,PLSTC:1UF,10%,50V	01884	LP88A1A105K
C304	281-0529-00			CAP.,FXD,CER DI:1.5PF,0.25PF,500V	72982	301-000C0K0159C
C309	281-0626-00			CAP.,FXD,CER DI:3.3PF,1%,500V	72982	301-000C0J0339B
C310	281-0626-00			CAP.,FXD,CER DI:3.3PF,1%,500V	72982	301-000C0J0339B
C311	281-0626-00			CAP.,FXD,CER DI:3.3PF,1%,500V	72982	301-000C0J0339B
C354	290-0535-00			CAP.,FXD,ELCTLT:33UF,20%,10V	56289	196D336X0010KAL
C371	283-0111-00			CAP.,FXD,CER DI:0.1UF,20%,50V	72982	8131N075651104M
C373	290-0535-00			CAP.,FXD,ELCTLT:33UF,20%,10V	56289	196D336X0010KAL
C376	281-0620-00			CAP.,FXD,CER DI:21PF,1%,500V	72982	301-000C0G0210F
C379	285-1031-00			CAP.,FXD,PLSTC:0.56UF,10%,50V	84411	TEK-116
C380	283-0081-00	XB040000		CAP.,FXD,CER DI:0.1UF,+80-20%,25V	56289	36C600
C381	283-0111-00			CAP.,FXD,CER DI:0.1UF,20%,50V	72982	8131N075651104M
C386	283-0000-00			CAP.,FXD,CER DI:0.001UF,+100-0%,500V	72982	831-516E102P
C390	281-0524-00			CAP.,FXD,CER DI:150PF,+/-30PF,500V	72982	301-000X5U0151M
C407	290-0136-00			CAP.,FXD,ELCTLT:2.2UF,20%,20V	56289	162D225X0020CD2
C409	290-0512-00			CAP.,FXD,ELCTLT:22UF,20%,15V	56285	196D226X0015KAL
C419	283-0000-00			CAP.,FXD,CER DI:0.001UF,+100-0%,500V	72982	831-516E102P
C430	281-0612-00			CAP.,FXD,CER DI:5.6PF,+/-0.5PF,500V	72982	374-001C0H0569D
C440	290-0530-00			CAP.,FXD,ELCTLT:68UF,20%,6V	90201	TDC686M006FL
C444	283-0198-00			CAP.,FXD,CER DI:0.22UF,20%,50V	72982	8131N075651224M
C453	283-0028-00			CAP.,FXD,CER DI:0.0022UF,20%,50V	56289	19C606
C466	281-0524-00			CAP.,FXD,CER DI:150PF,+/-30PF,500V	72982	301-000X5U0151M
C467	281-0524-00			CAP.,FXD,CER DI:150PF,+/-30PF,500V	72982	301-000X5U0151M
C470	281-0525-00			CAP.,FXD,CER DI:470PF,+/-94PF,500V	72982	301-000X5U0471M
C471	290-0523-00			CAP.,FXD,ELCTLT:2.2UF,20%,20V	56289	196D225X0025HA1

Electrical Parts List—7D12

Ckt No.	Tektronix Part No.	Serial/Model No. Eff	Dscont	Name & Description	Mfr Code	Mfr Part Number
C477	281-0524-00			CAP.,FXD,CER DI:150PF,+/-30PF,500V	72982	301-000X5U0151M
C483	281-0579-00			CAP.,FXD,CER DI:21PF,5%,500V	72982	301-050C0G0210J
C485	281-0525-00	B010100	B029999	CAP.,FXD,CER DI:470PF,+/-94PF,500V	72982	301-000X5U0471M
C485	283-0003-00	B030000		CAP.,FXD,CER DI:0.01UF,+80-20%,150V	72982	855-547E103Z
C488	281-0525-00	B010100	B029999	CAP.,FXD,CER DI:470PF,+/-94PF,500V	72982	301-000X5U0471M
C488	283-0065-00	B030000		CAP.,FXD,CER DI:0.001UF,5%,100V	72982	805-505B102J
C493	283-0068-00			CAP.,FXD,CER DI:0.01UF,+100-0%,500V	56289	19C241
C495	281-0605-00			CAP.,FXD,CER DI:200PF,10%,500V	72982	301-000Y5D0201K
C497	281-0524-00			CAP.,FXD,CER DI:150PF,+/-30PF,500V	72982	301-000X5U0151M
C500	283-0028-00			CAP.,FXD,CER DI:0.0022UF,20%,50V	56289	19C606
C505	281-0524-00			CAP.,FXD,CER DI:150PF,+/-30PF,500V	72982	301-000X5U0151M
C511	281-0524-00			CAP.,FXD,CER DI:150PF,+/-30PF,500V	72982	301-000X5U0151M
C517	281-0524-00			CAP.,FXD,CER DI:150PF,+/-30PF,500V	72982	301-000X5U0151M
C561	283-0177-00			CAP.,FXD,CER DI:1UF,+80-20%,25V	72982	8131N039651105Z
C563	283-0177-00			CAP.,FXD,CER DI:1UF,+80-20%,25V	72982	8131N039651105Z
C566	283-0177-00			CAP.,FXD,CER DI:1UF,+80-20%,25V	72982	8131N039651105Z
C569	283-0081-00			CAP.,FXD,CER DI:0.1UF,+80-20%,25V	56289	36C600
C571	283-0081-00			CAP.,FXD,CER DI:0.1UF,+80-20%,25V	56289	36C600
C573	283-0081-00			CAP.,FXD,CER DI:0.1UF,+80-20%,25V	56289	36C600
C575	283-0081-00			CAP.,FXD,CER DI:0.1UF,+80-20%,25V	56289	36C600
C577	283-0081-00			CAP.,FXD,CER DI:0.1UF,+80-20%,25V	56289	36C600
C579	283-0177-00			CAP.,FXD,CER DI:1UF,+80-20%,25V	72982	8131N039651105Z
C581	283-0111-00			CAP.,FXD,CER DI:0.1UF,20%,50V	72982	8131N075651104M
C583	290-0162-00			CAP.,FXD,ELCTLT:22UF,20%,35V	56289	150D226X0035R2
C585	283-0111-00			CAP.,FXD,CER DI:0.1UF,20%,50V	72982	8131N075651104M
C588	283-0111-00			CAP.,FXD,CER DI:0.1UF,20%,50V	72982	8131N075651104M
C593	281-0064-00			CAP.,VAR,PLSTC:0.25-1.5PF,600V	72982	530-002
C594	281-0661-00			CAP.,FXD,CER DI:0.8PF,+/-0.1PF,500V	72982	301-000C0G0808B
C598	283-0111-00			CAP.,FXD,CER DI:0.1UF,20%,50V	72982	8131N075651104M
C603	281-0557-00			CAP.,FXD,CER DI:1.8PF,10%,500V	72982	301-000C0K0189B
C604	281-0529-00			CAP.,FXD,CER DI:1.5PF,0.25PF,500V	72982	301-000C0K0159C
C609	290-0135-00			CAP.,FXD,ELCTLT:15UF,20%,20V	06751	TS2K20-156
C612	290-0135-00			CAP.,FXD,ELCTLT:15UF,20%,20V	06751	TS2K20-156
C613	283-0111-00			CAP.,FXD,CER DI:0.1UF,20%,50V	72982	8131N075651104M
C630	290-0134-00			CAP.,FXD,ELCTLT:22UF,20%,15V	56289	150D226X0015B2
C631	283-0111-00			CAP.,FXD,CER DI:0.1UF,20%,50V	72982	8131N075651104M
C633	290-0512-00			CAP.,FXD,ELCTLT:22UF,20%,15V	56285	196D226X0015KA1
C635	290-0135-00			CAP.,FXD,ELCTLT:15UF,20%,20V	06751	TS2K20-156
C647	290-0134-00			CAP.,FXD,ELCTLT:22UF,20%,15V	56289	150D226X0015B2
C648	283-0111-00			CAP.,FXD,CER DI:0.1UF,20%,50V	72982	8131N075651104M
C649	290-0135-00			CAP.,FXD,ELCTLT:15UF,20%,20V	06751	TS2K20-156
C650	290-0512-00			CAP.,FXD,ELCTLT:22UF,20%,15V	56285	196D226X0015KA1
C652	290-0512-00			CAP.,FXD,ELCTLT:22UF,20%,15V	56285	196D226X0015KA1
C657	290-0297-00			CAP.,FXD,ELCTLT:39UF,10%,10V	56289	150D396X9010B2
C658	290-0297-00			CAP.,FXD,ELCTLT:39UF,10%,10V	56289	150D396X9010B2
C666	290-0114-00			CAP.,FXD,ELCTLT:47UF,20%,6V	56289	150D476X0006B2
C667	283-0111-00			CAP.,FXD,CER DI:0.1UF,20%,50V	72982	8131N075651104M
CR172	152-0075-00			SEMICOND DEVICE:GE,25V,40MA	72982	ED48
CR226	152-0321-00			SEMICOND DEVICE:SILICON,35V,100MA	07263	FSA1480
CR263	152-0324-00			SEMICOND DEVICE:SILICON,35V,100MA	03508	SE416
CR279	152-0324-00			SEMICOND DEVICE:SILICON,35V,100MA	03508	SE416
CR338	152-0324-00			SEMICOND DEVICE:SILICON,35V,100MA	03508	SE416
CR339	152-0324-00			SEMICOND DEVICE:SILICON,35V,100MA	03508	SE416
CR364	152-0324-00			SEMICOND DEVICE:SILICON,35V,100MA	03508	SE416
CR365	152-0324-00			SEMICOND DEVICE:SILICON,35V,100MA	03508	SE416
CR385	152-0141-02			SEMICOND DEVICE:SILICON,30V,150MA	07910	CD8220
CR386	152-0141-02			SEMICOND DEVICE:SILICON,30V,150MA	07910	CD8220
CR417	152-0071-00			SEMICOND DEVICE:GERMANIUM,15V,40MA	14433	G865
CR432	152-0141-02			SEMICOND DEVICE:SILICON,30V,150MA	07910	CD8220
CR438	150-1004-00			LAMP,LED:RED,2.5V,15MA	03508	SSL-12
CR440	152-0141-02			SEMICOND DEVICE:SILICON,30V,150MA	07910	CD8220
CR460	152-0075-00			SEMICOND DEVICE:GE,25V,40MA	72982	ED48

Ckt No.	Tektronix Part No.	Serial/Model No.		Name & Description	Mfr Code	Mfr Part Number	
		Eff	Dscont				
CR462	152-0075-00			SEMICOND DEVICE:GE,25V,40MA	72982	ED48	
CR500	152-0322-00			SEMICOND DEVICE:SILICON,10V,100NA	01295	A1108	
CR526	152-0141-02			SEMICOND DEVICE:SILICON,30V,150MA	07910	CD8220	
CR535	152-0141-02			SEMICOND DEVICE:SILICON,30V,150MA	07910	CD8220	
CR542	152-0141-02			SEMICOND DEVICE:SILICON,30V,150MA	07910	CD8220	
CR549	152-0141-02			SEMICOND DEVICE:SILICON,30V,150MA	07910	CD8220	
CR554	152-0141-02			SEMICOND DEVICE:SILICON,30V,150MA	07910	CD8220	
CR587	152-0141-02			SEMICOND DEVICE:SILICON,30V,150MA	07910	CD8220	
CR589	152-0141-02			SEMICOND DEVICE:SILICON,30V,150MA	07910	CD8220	
CR597	152-0141-02			SEMICOND DEVICE:SILICON,30V,150MA	07910	CD8220	
CR599	152-0141-02			SEMICOND DEVICE:SILICON,30V,150MA	07910	CD8220	
CR606	152-0426-00			SEMICOND DEVICE:SILICON,400V,400MA	80009	152-0426-00	
CR607	152-0426-00			SEMICOND DEVICE:SILICON,400V,400MA	80009	152-0426-00	
CR608	152-0426-00			SEMICOND DEVICE:SILICON,400V,400MA	80009	152-0426-00	
CR609	152-0426-00			SEMICOND DEVICE:SILICON,400V,400MA	80009	152-0426-00	
CR655	152-0413-00			SEMICOND DEVICE:SILICON,400V,750MA	04713	MR814	
CR656	152-0413-00			SEMICOND DEVICE:SILICON,400V,750MA	04713	MR814	
DS416	150-0048-01			LAMP, INCAND:NO.683,SELECTED	80009	150-0048-01	
F581	159-0094-00			FUSE,WIRE LEAD:0.75A,125V,FAST-BLO	75915	273750	
F585	159-0094-00			FUSE,WIRE LEAD:0.75A,125V,FAST-BLO	75915	273750	
J181	131-1003-00			CONN,RECP,ELEC:CKT BD MT,3 PRONG	80009	131-1003-00	
J183	131-1003-00			CONN,RECP,ELEC:CKT BD MT,3 PRONG	80009	131-1003-00	
J207	131-1003-00			CONN,RECP,ELEC:CKT BD MT,3 PRONG	80009	131-1003-00	
J209	131-1003-00			CONN,RECP,ELEC:CKT BD MT,3 PRONG	80009	131-1003-00	
J217	131-1003-00			CONN,RECP,ELEC:CKT BD MT,3 PRONG	80009	131-1003-00	
J219	131-1003-00			CONN,RECP,ELEC:CKT BD MT,3 PRONG	80009	131-1003-00	
J415	131-0955-00			CONN,RECP,ELEC:BNC,FEMALE	24931	28JR200-1	
J426	131-1003-00			CONN,RECP,ELEC:CKT BD MT,3 PRONG	80009	131-1003-00	
J587	131-1003-00			CONN,RECP,ELEC:CKT BD MT,3 PRONG	80009	131-1003-00	
J597	131-1003-00			CONN,RECP,ELEC:CKT BD MT,3 PRONG	80009	131-1003-00	
L563	108-0245-00			COIL,RF:3.9UH	76493	B6310-1	
L566	108-0245-00			COIL,RF:3.9UH	76493	B6310-1	
L579	108-0245-00			COIL,RF:3.9UH	76493	B6310-1	
L581	108-0406-00			COIL,RF:80UH,TOROIDAL	80009	108-0406-00	
L585	108-0406-00			COIL,RF:80UH,TOROIDAL	80009	108-0406-00	
L609	108-0016-00	B010100	B049999	COIL,RF:29UH	80009	108-0016-00	
L609	108-0406-00	B050000		COIL,RF:80UH,TOROIDAL	80009	108-0406-00	
L635	108-0406-00			COIL,RF:80UH,TOROIDAL	80009	108-0406-00	
L657	108-0406-00			COIL,RF:80UH,TOROIDAL	80009	108-0406-00	
Q144	151-0190-00	B010100	B039999X	TRANSISTOR:SILICON,NPN	04713	2N3904	
Q170	151-0402-00			TRANSISTOR:SILICON,NPN	80009	151-0402-00	
Q177	151-0434-00			TRANSISTOR:SILICON,PNP	04713	2N4261	
Q190	151-0221-00			TRANSISTOR:SILICON,PNP	07263	S24849	
Q200	151-0221-00			TRANSISTOR:SILICON,PNP	07263	S24849	
Q224	151-0190-00			TRANSISTOR:SILICON,NPN	04713	2N3904	
Q228	151-0342-00			TRANSISTOR:SILICON,PNP	07263	2N4249	
Q233	151-1067-00			TRANSISTOR:SILICON,MOSFE	80009	151-1067-00	
Q237	151-1067-00			TRANSISTOR:SILICON,MOSFE	80009	151-1067-00	
Q242	151-0342-00			TRANSISTOR:SILICON,PNP	07263	2N4249	
Q244	151-1068-00			TRANSISTOR:JFE,N CHANNEL	17856	2N4340	
Q246	151-0254-00			TRANSISTOR:SILICON,NPN	03508	2N5308	
Q250	151-0342-00			TRANSISTOR:SILICON,PNP	07263	2N4249	
Q252	151-0342-00			TRANSISTOR:SILICON,PNP	07263	2N4249	
Q254	151-0254-00			TRANSISTOR:SILICON,NPN	03508	2N5308	
Q262	153-0549-00			TRANSISTOR:SILICON,JFE,N CHANNEL,SELECTED	80009	153-0549-00	
Q267	151-1004-00			TRANSISTOR:SILICON,JFE,N CHANNEL	17856	FN684	
Q270	151-1004-00			TRANSISTOR:SILICON,JFE,N CHANNEL	17856	FN684	
Q275	153-0549-00			TRANSISTOR:SILICON,JFE,N CHANNEL,SELECTED	80009	153-0549-00	
Q278	151-0190-00			TRANSISTOR:SILICON,NPN	04713	2N3904	

Electrical Parts List-7D12

Ckt No.	Tektronix Part No.	Serial/Model No.		Name & Description	Mfr Code	Mfr Part Number
		Eff	Dscont			
Q287	151-0190-00			TRANSISTOR:SILICON,NPN	04713	2N3904
Q290	151-1005-00			TRANSISTOR:SILICON,JFE,N CHANNEL	15818	U1490
Q296	153-0549-00			TRANSISTOR:SILICON,JFE,N CHANNEL,SELECTED	80009	153-0549-00
Q298	151-0190-00			TRANSISTOR:SILICON,NPN	04713	2N3904
Q306	151-0188-00			TRANSISTOR:SILICON,PNP	04713	2N3906
Q313	151-0188-00			TRANSISTOR:SILICON,PNP	04713	2N3906
Q321	151-0190-00			TRANSISTOR:SILICON,NPN	04713	2N3904
Q329	151-0190-00			TRANSISTOR:SILICON,NPN	04713	2N3904
Q332	151-0188-00			TRANSISTOR:SILICON,PNP	04713	2N3906
Q336	151-1005-00			TRANSISTOR:SILICON,JFE,N CHANNEL	15818	U1490
Q344	151-0190-00			TRANSISTOR:SILICON,NPN	04713	2N3904
Q353	151-0254-00			TRANSISTOR:SILICON,NPN	03508	2N5308
Q363	151-1045-00			TRANSISTOR:SILICON,JFE,P CHANNEL	04713	2N5460
Q367	153-0549-00			TRANSISTOR:SILICON,JFE,N CHANNEL,SELECTED	80009	153-0549-00
Q369	151-0190-00			TRANSISTOR:SILICON,NPN	04713	2N3904
Q376	151-0188-00			TRANSISTOR:SILICON,PNP	04713	2N3906
Q378	151-0190-00			TRANSISTOR:SILICON,NPN	04713	2N3904
Q404	151-0190-00			TRANSISTOR:SILICON,NPN	04713	2N3904
Q410	151-0504-00			TRANSISTOR:SILICON,UNI JUNCTION	04713	2N4851
Q434	151-0225-00			TRANSISTOR:SILICON,NPN	07910	CS23366
Q480	151-0367-00			TRANSISTOR:SILICON,NPN,SEL FROM 3571TP	80009	151-0367-00
Q507	151-0190-00			TRANSISTOR:SILICON,NPN	04713	2N3904
Q524	151-0190-00			TRANSISTOR:SILICON,NPN	04713	2N3904
Q532	151-0190-00			TRANSISTOR:SILICON,NPN	04713	2N3904
Q540	151-0190-00			TRANSISTOR:SILICON,NPN	04713	2N3904
Q547	151-0190-00			TRANSISTOR:SILICON,NPN	04713	2N3904
Q552	151-0190-00			TRANSISTOR:SILICON,NPN	04713	2N3904
Q590	151-0347-00			TRANSISTOR:SILICON,NPN	07263	S35939
Q593	151-0426-00			TRANSISTOR:SILICON,NPN	03508	044H11
Q600	151-0347-00			TRANSISTOR:SILICON,NPN	07263	S35939
Q603	151-0426-00			TRANSISTOR:SILICON,NPN	03508	044H11
Q620	151-0342-00			TRANSISTOR:SILICON,PNP	07263	2N4249
Q622	151-0235-00			TRANSISTOR:SILICON,PNP	04713	2N4890
Q626	151-0190-00			TRANSISTOR:SILICON,NPN	04713	2N3904
Q637	151-0190-00			TRANSISTOR:SILICON,NPN	04713	2N3904
Q646	151-0260-00			TRANSISTOR:SILICON,NPN	02735	2N5189
Q661	151-0235-00			TRANSISTOR:SILICON,PNP	04713	2N4890
Q664	151-0190-00			TRANSISTOR:SILICON,NPN	04713	2N3904
R102	315-0431-00			RES.,FXD,COMP:430 OHM,5%,0.25W	01121	CB4315
R104	321-0172-00			RES.,FXD,FILM:604 OHM,1%,0.125W	75042	CEAT0-6040F
R105	321-0155-00			RES.,FXD,FILM:402 OHM,1%,0.125W	75042	CEAT0-4020F
R106	315-0511-00	B010100	B039999	RES.,FXD,COMP:510 OHM,5%,0.25W	01121	CB5115
R106	315-0751-00	B040000		RES.,FXD,COMP:750 OHM,5%,0.25W	01121	CB7515
R108	321-0184-00			RES.,FXD,FILM:806 OHM,1%,0.125W	75042	CEAT0-8060F
R109	321-0126-00			RES.,FXD,FILM:200 OHM,1%,0.125W	75042	CEAT0-2000F
R110	315-0301-00			RES.,FXD,COMP:300 OHM,5%,0.25W	01121	CB3015
R111	321-0190-00			RES.,FXD,FILM:931 OHM,1%,0.125W	75042	CEAT0-9310F
R112	321-0087-00			RES.,FXD,FILM:78.7 OHM,1%,0.125W	75042	CEAT0-78R70F
R114	315-0753-00			RES.,FXD,COMP:75K OHM,5%,0.25W	01121	CB7535
R115	315-0154-00			RES.,FXD,COMP:150K OHM,5%,0.25W	01121	CB1545
R116	321-0344-00			RES.,FXD,FILM:37.4K OHM,1%,0.124W	75042	CEAT0-3742F
R120	311-0642-00			RES.,VAR,NONWIR:20K OHM,10%,0.5W	12697	382-CM39820
R122	315-0204-00			RES.,FXD,COMP:200K OHM,5%,0.25W	01121	CB2045
R123	315-0562-00			RES.,FXD,COMP:5.6K OHM,5%,0.25W	01121	CB5625
R125	315-0300-00			RES.,FXD,COMP:30 OHM,5%,0.25W	01121	CB3005
R127	321-0072-00			RES.,FXD,FILM:54.9 OHM,1%,0.125W	75042	CEAT0-54R90F
R128	321-0025-00			RES.,FXD,FILM:17.8 OHM,1%,0.125W	75042	CEAT0-17R80F
R129	321-0050-00			RES.,FXD,FILM:32.4 OHM,1%,0.125W	75042	CEAT0-32R40F
R131	311-0881-00			RES.,VAR,NONWIR:20K OHM,10%	01121	W7674
R133	315-0204-00			RES.,FXD,COMP:200K OHM,5%,0.25W	01121	CB2045

Electrical Parts List-7D12

Ckt No.	Tektronix		Serial/Model No.		Name & Description	Mfr Code	Mfr Part Number
	Part No.	Eff	Dscont				
R134	315-0822-00				RES.,FXD,COMP:8.2K OHM,5%,0.25W	01121	CB8225
R136	315-0300-00				RES.,FXD,COMP:30 OHM,5%,0.25W	01121	CB3005
R138	311-1230-00				RES.,VAR,NONWIR:20K OHM,20%,0.50W	80294	3389F-P31-203
R139	315-0753-00				RES.,FXD,COMP:75K OHM,5%,0.25W	01121	CB7535
R140	315-0201-00				RES.,FXD,COMP:200 OHM,5%,0.25W	01121	CB2015
R142	315-0512-00	B010100	B039999		RES.,FXD,COMP:5.1K OHM,5%,0.25W	01121	CB5125
R142	315-0272-00	B040000			RES.,FXD,COMP:2.7K OHM,5%,0.25W	01121	CB2725
R143	315-0512-00	B010100	B039999		RES.,FXD,COMP:5.1K OHM,5%,0.25W	01121	CB5125
R143	315-0272-00	B040000			RES.,FXD,COMP:2.7K OHM,5%,0.25W	01121	CB2725
R145	315-0432-00	B010100	B039999		RES.,FXD,COMP:4.3K OHM,5%,0.25W	01121	CB4325
R145	315-0272-00	B040000			RES.,FXD,COMP:2.7K OHM,5%,0.25W	01121	CB2725
R146	315-0102-00				RES.,FXD,COMP:1K OHM,5%,0.25W	01121	CB1025
R150	321-0217-00				RES.,FXD,FILM:1.78K OHM,1%,0.125W	75042	CEAT0-1781F
R152	315-0201-00				RES.,FXD,COMP:200 OHM,5%,0.25W	01121	CB2015
R154	315-0430-00				RES.,FXD,COMP:43 OHM,5%,0.25W	01121	CB4305
R155	315-0430-00				RES.,FXD,COMP:43 OHM,5%,0.25W	01121	CB4305
R156	315-0911-00				RES.,FXD,COMP:910 OHM,5%,0.25W	01121	CB9115
R158	315-0152-00				RES.,FXD,COMP:1.5K OHM,5%,0.25W	01121	CB1525
R160	321-0059-00				RES.,FXD,FILM:40.2 OHM,1%,0.125W	75042	CEAT0-40R20F
R161	321-0059-00				RES.,FXD,FILM:40.2 OHM,1%,0.125W	75042	CEAT0-40R20F
R162	323-0189-00				RES.,FXD,FILM:909 OHM,1%,0.50W	75042	CECT0-9090F
R164	315-0392-00				RES.,FXD,COMP:3.9K OHM,5%,0.25W	01121	CB3925
R165	315-0241-00				RES.,FXD,COMP:240 OHM,5%,0.25W	01121	CB2415
R167	315-0431-00				RES.,FXD,COMP:430 OHM,5%,0.25W	01121	CB4315
R169	311-1264-00				RES.,VAR,NONWIR:1.5K OHM,10%,0.50W	80294	3329P-L58-152
R170	315-0361-00				RES.,FXD,COMP:360 OHM,5%,0.25W	01121	CB3615
R172	315-0222-00				RES.,FXD,COMP:2.2K OHM,5%,0.25W	01121	CB2225
R173	315-0121-00				RES.,FXD,COMP:120 OHM,5%,0.25W	01121	CB1215
R177	315-0510-00				RES.,FXD,COMP:51 OHM,5%,0.25W	01121	CB5105
R178	315-0102-00				RES.,FXD,COMP:1K OHM,5%,0.25W	01121	CB1025
R179	315-0431-00				RES.,FXD,COMP:430 OHM,5%,0.25W	01121	CB4315
R181	315-0510-00				RES.,FXD,COMP:51 OHM,5%,0.25W	01121	CB5105
R184	321-0091-00				RES.,FXD,FILM:86.6 OHM,1%,0.125W	75042	CEAT0-86R60F
R186	322-0173-00				RES.,FXD,FILM:619 OHM,1%,0.25W	75042	CEBT0-6190F
R187	321-0126-00				RES.,FXD,FILM:200 OHM,1%,0.125W	75042	CEAT0-2000F
R188	322-0173-00				RES.,FXD,FILM:619 OHM,1%,0.25W	75042	CEBT0-6190F
R191	322-0612-00				RES.,FXD,FILM:500 OHM,1%,0.25W	75042	CEBT0-5000F
R193	321-0075-00				RES.,FXD,FILM:59 OHM,1%,0.125W	75042	CEAT0-59R00F
R195	311-1263-00				RES.,VAR,NONWIR:1K OHM,10%,0.50W	73138	62PT-347-0
R196	315-0751-00				RES.,FXD,COMP:750 OHM,5%,0.25W	01121	CB7515
R197	315-0102-00				RES.,FXD,COMP:1K OHM,5%,0.25W	01121	CB1025
R198	315-0330-00				RES.,FXD,COMP:33 OHM,5%,0.25W	01121	CB3305
R201	322-0612-00				RES.,FXD,FILM:500 OHM,1%,0.25W	75042	CEBT0-5000F
R203	315-0201-00				RES.,FXD,COMP:200 OHM,5%,0.25W	01121	CB2015
R205	321-0068-00				RES.,FXD,FILM:49.9 OHM,1%,0.125W	75042	CEAT0-49R90F
R206	301-0102-00				RES.,FXD,COMP:1K OHM,5%,0.50W	01121	EB1025
R213	315-0201-00				RES.,FXD,COMP:200 OHM,5%,0.25W	01121	CB2015
R215	321-0068-00				RES.,FXD,FILM:49.9 OHM,1%,0.125W	75042	CEAT0-49R90F
R216	301-0102-00				RES.,FXD,COMP:1K OHM,5%,0.50W	01121	EB1025
R221	315-0302-00				RES.,FXD,COMP:3K OHM,5%,0.25W	01121	CB3025
R222	315-0273-00				RES.,FXD,COMP:27K OHM,5%,0.25W	01121	CB2735
R225	315-0203-00				RES.,FXD,COMP:20K OHM,5%,0.25W	01121	CB2035
R227	315-0102-00				RES.,FXD,COMP:1K OHM,5%,0.25W	01121	CB1025
R228	315-0203-00				RES.,FXD,COMP:20K OHM,5%,0.25W	01121	CB2035
R230	315-0153-00				RES.,FXD,COMP:15K OHM,5%,0.25W	01121	CB1535
R231	315-0752-00				RES.,FXD,COMP:7.5K OHM,5%,0.25W	01121	CB7525
R236	315-0103-00				RES.,FXD,COMP:10K OHM,5%,0.25W	01121	CB1035
R239	315-0302-00				RES.,FXD,COMP:3K OHM,5%,0.25W	01121	CB3025
R240	315-0123-00				RES.,FXD,COMP:12K OHM,5%,0.25W	01121	CB1235
R242	315-0241-00				RES.,FXD,COMP:240 OHM,5%,0.25W	01121	CB2415
R248	315-0821-00				RES.,FXD,COMP:820 OHM,5%,0.25W	01121	CB8215
R249	311-1227-00				RES.,VAR,NONWIR:5K OHM,20%,0.50W	80294	3389F-P31-502
R252	315-0474-00				RES.,FXD,COMP:470K OHM,5%,0.25W	01121	CB4745

Electrical Parts List-7D12

Ckt No.	Tektronix Part No.	Serial/Model No.		Name & Description	Mfr Code	Mfr Part Number
		Eff	Dscont			
R257	315-0272-00			RES.,FXD,COMP:2.7K OHM,5%,0.25W	01121	CB2725
R265	315-0562-00			RES.,FXD,COMP:5.6K OHM,5%,0.25W	01121	CB5625
R266	315-0242-00			RES.,FXD,COMP:2.4 OHM,5%,0.25W	01121	CB2425
R269 <sup>1</sup>	307-0380-00			RES.,FXD,FILM:6.66K OHM,0.1%,0.125W	18612	V-53-1-311054
R271	315-0242-00			RES.,FXD,COMP:2.4 OHM,5%,0.25W	01121	CB2425
R279	315-0242-00			RES.,FXD,COMP:2.4 OHM,5%,0.25W	01121	CB2425
R281	315-0104-00			RES.,FXD,COMP:100K OHM,5%,0.25W	01121	CB1045
R285	315-0622-00			RES.,FXD,COMP:6.2K OHM,5%,0.25W	01121	CB6225
R286	315-0153-00			RES.,FXD,COMP:15K OHM,5%,0.25W	01121	CB1535
R289	315-0391-00			RES.,FXD,COMP:390 OHM,5%,0.25W	01121	CB3915
R290	315-0474-00			RES.,FXD,COMP:470K OHM,5%,0.25W	01121	CB4745
R291	315-0273-00			RES.,FXD,COMP:27K OHM,5%,0.25W	01121	CB2735
R293	315-0123-00			RES.,FXD,COMP:12K OHM,5%,0.25W	01121	CB1235
R299	315-0242-00			RES.,FXD,COMP:2.4 OHM,5%,0.25W	01121	CB2425
R307	315-0203-00			RES.,FXD,COMP:20K OHM,5%,0.25W	01121	CB2035
R309	315-0103-00			RES.,FXD,COMP:10K OHM,5%,0.25W	01121	CB1035
R310	315-0102-00			RES.,FXD,COMP:1K OHM,5%,0.25W	01121	CB1025
R312	315-0203-00			RES.,FXD,COMP:20K OHM,5%,0.25W	01121	CB2035
R314	315-0103-00			RES.,FXD,COMP:10K OHM,5%,0.25W	01121	CB1035
R315	315-0102-00			RES.,FXD,COMP:1K OHM,5%,0.25W	01121	CB1025
R319	315-0102-00			RES.,FXD,COMP:1K OHM,5%,0.25W	01121	CB1025
R321	315-0302-00			RES.,FXD,COMP:3K OHM,5%,0.25W	01121	CB3025
R322	315-0223-00			RES.,FXD,COMP:220K OHM,5%,0.25W	01121	CB2235
R323	315-0152-00			RES.,FXD,COMP:1.5K OHM,5%,0.25W	01121	CB1525
R327	315-0152-00			RES.,FXD,COMP:1.5K OHM,5%,0.25W	01121	CB1525
R328	315-0223-00			RES.,FXD,COMP:220K OHM,5%,0.25W	01121	CB2235
R329	315-0202-00			RES.,FXD,COMP:2K OHM,5%,0.25W	01121	CB2025
R331	315-0103-00			RES.,FXD,COMP:10K OHM,5%,0.25W	01121	CB1035
R332	315-0202-00			RES.,FXD,COMP:2K OHM,5%,0.25W	01121	CB2025
R333	315-0112-00			RES.,FXD,COMP:1.1K OHM,5%,0.25W	01121	CB1125
R335	315-0203-00			RES.,FXD,COMP:20K OHM,5%,0.25W	01121	CB2035
R341	315-0102-00			RES.,FXD,COMP:1K OHM,5%,0.25W	01121	CB1025
R344	315-0302-00			RES.,FXD,COMP:3K OHM,5%,0.25W	01121	CB3025
R346	315-0223-00			RES.,FXD,COMP:220K OHM,5%,0.25W	01121	CB2235
R347	315-0152-00			RES.,FXD,COMP:1.5K OHM,5%,0.25W	01121	CB1525
R350	321-0197-02			RES.,FXD,FILM:1.1K OHM,0.5%,0.125W	75042	CEAT2-1101D
R353	321-0911-02			RES.,FXD,FILM:829 OHM,0.5%,0.125W	75042	CEAT2-8290D
R357	315-0202-00			RES.,FXD,COMP:2K OHM,5%,0.25W	01121	CB2025
R359	321-0799-02			RES.,FXD,FILM:146.8 OHM,(NOM VALUE),SEL	75042	CEAT2-146R8D
R360	321-0799-02			RES.,FXD,FILM:146.8 OHM,(NOM VALUE),SEL	75042	CEAT2-146R8D
R361 <sup>1</sup>	311-1167-00			RES.,VAR,NONWIR:200 OHM,20%,0.5W	80294	3009P-1-201
R362	307-0380-00			RES.,FXD,FILM:20.9K OHM,0.1%,0.125W	18612	V-53-1-311054
R369	315-0242-00			RES.,FXD,COMP:2.4 OHM,5%,0.25W	01121	CB2425
R371	315-0122-00			RES.,FXD,COMP:1.2K OHM,5%,0.25W	01121	CB1225
R372	315-0153-00			RES.,FXD,COMP:15K OHM,5%,0.25W	01121	CB1535
R373	315-0512-00			RES.,FXD,COMP:5.1K OHM,5%,0.25W	01121	CB5125
R377	315-0361-00			RES.,FXD,COMP:360 OHM,5%,0.25W	01121	CB3615
R379	315-0132-00			RES.,FXD,COMP:1.3K OHM,5%,0.25W	01121	CB1325
R381	315-0102-00			RES.,FXD,COMP:1K OHM,5%,0.25W	01121	CB1025
R383	315-0622-00			RES.,FXD,COMP:6.2K OHM,5%,0.25W	01121	CB6225
R385	315-0821-00			RES.,FXD,COMP:820 OHM,5%,0.25W	01121	CB8215
R386	315-0752-00			RES.,FXD,COMP:7.5K OHM,5%,0.25W	01121	CB7525
R388	315-0821-00			RES.,FXD,COMP:820 OHM,5%,0.25W	01121	CB8215
R390	315-0821-00			RES.,FXD,COMP:820 OHM,5%,0.25W	01121	CB8215
R401	315-0432-00			RES.,FXD,COMP:4.3K OHM,5%,0.25W	01121	CB4325
R404	315-0391-00			RES.,FXD,COMP:390 OHM,5%,0.25W	01121	CB3915
R407	315-0913-00			RES.,FXD,COMP:91K OHM,5%,0.25W	01121	CB9135
R409	315-0101-00			RES.,FXD,COMP:100 OHM,5%,0.25W	01121	CB1015
R410	315-0221-00			RES.,FXD,COMP:220 OHM,5%,0.25W	01121	CB2215
R412	307-0110-00			RES.,FXD,COMP:3 OHM,5%,0.25W	01121	CB30G5

<sup>1</sup>Furnished as a unit.



Ckt No.	Tektronix Part No.	Serial/Model No.		Name & Description	Mfr Code	Mfr Part Number
		Eff	Dscont			
R419	315-0396-00			RES.,FXD,COMP:39M OHM,5%,0.25W	01121	CB3965
R420	315-0391-00			RES.,FXD,COMP:390 OHM,5%,0.25W	01121	CB3915
R422	315-0103-00			RES.,FXD,COMP:10K OHM,5%,0.25W	01121	CB1035
R430	315-0103-00			RES.,FXD,COMP:10K OHM,5%,0.25W	01121	CB1035
R432	315-0473-00			RES.,FXD,COMP:47K OHM,5%,0.25W	01121	CB4735
R434	315-0512-00			RES.,FXD,COMP:5.1K OHM,5%,0.25W	01121	CB5125
R437	315-0471-00			RES.,FXD,COMP:470 OHM,5%,0.25W	01121	CB4715
R440	321-0247-00			RES.,FXD,FILM:3.65K OHM,1%,0.125W	75042	CEAT0-3651F
R441	311-1556-00	B010100	B019999	RES.,VAR,NONWIR:50K OHM,20%,0.50W	73138	91A-50001M
R441	311-1271-00	B020000		RES.,VAR,NONWIR:50K OHM,10%,0.50W	73138	62PT-354-0
R442	315-0102-00			RES.,FXD,COMP:1K OHM,5%,0.25W	01121	CB1025
R444	321-0335-00			RES.,FXD,FILM:30.1K OHM,1%,0.125W	75042	CEAT0-3012F
R446	315-0272-00			RES.,FXD,COMP:2.7K OHM,5%,0.25W	01121	CB2725
R448	315-0272-00			RES.,FXD,COMP:2.7K OHM,5%,0.25W	01121	CB2725
R450	315-0272-00			RES.,FXD,COMP:2.7K OHM,5%,0.25W	01121	CB2725
R452	315-0272-00			RES.,FXD,COMP:2.7K OHM,5%,0.25W	01121	CB2725
R455	315-0102-00			RES.,FXD,COMP:1K OHM,5%,0.25W	01121	CB1025
R460	315-0102-00			RES.,FXD,COMP:1K OHM,5%,0.25W	01121	CB1025
R462	315-0102-00			RES.,FXD,COMP:1K OHM,5%,0.25W	01121	CB1025
R465	315-0681-00			RES.,FXD,COMP:680 OHM,5%,0.25W	01121	CB6815
R466	315-0681-00			RES.,FXD,COMP:680 OHM,5%,0.25W	01121	CB6815
R467	315-0752-00			RES.,FXD,COMP:7.5K OHM,5%,0.25W	01121	CB7525
R468	315-0752-00			RES.,FXD,COMP:7.5K OHM,5%,0.25W	01121	CB7525
R470	315-0203-00			RES.,FXD,COMP:20K OHM,5%,0.25W	01121	CB2035
R471	315-0202-00			RES.,FXD,COMP:2K OHM,5%,0.25W	01121	CB2025
R477	315-0681-00			RES.,FXD,COMP:680 OHM,5%,0.25W	01121	CB6815
R478	315-0681-00			RES.,FXD,COMP:680 OHM,5%,0.25W	01121	CB6815
R480	315-0302-00			RES.,FXD,COMP:3K OHM,5%,0.25W	01121	CB3025
R482	315-0223-00			RES.,FXD,COMP:220K OHM,5%,0.25W	01121	CB2235
R483	315-0152-00			RES.,FXD,COMP:1.5K OHM,5%,0.25W	01121	CB1525
R485	315-0432-00			RES.,FXD,COMP:4.3K OHM,5%,0.25W	01121	CB4325
R486	315-0432-00			RES.,FXD,COMP:4.3K OHM,5%,0.25W	01121	CB4325
R488	315-0752-00			RES.,FXD,COMP:7.5K OHM,5%,0.25W	01121	CB7525
R489	315-0752-00			RES.,FXD,COMP:7.5K OHM,5%,0.25W	01121	CB7525
R491	315-0752-00			RES.,FXD,COMP:7.5K OHM,5%,0.25W	01121	CB7525
R493	315-0203-00			RES.,FXD,COMP:20K OHM,5%,0.25W	01121	CB2035
R497	315-0622-00			RES.,FXD,COMP:6.2K OHM,5%,0.25W	01121	CB6225
R499	311-1137-00			RES.,VAR,NONWIR:5K OHM,20%,0.5W	73138	72PX-67-0-502M
R500	321-0302-00			RES.,FXD,FILM:13.7K OHM,1%,0.125W	75042	CEAT0-1372F
R502	315-0104-00			RES.,FXD,COMP:100K OHM,5%,0.25W	01121	CB1045
R505	315-0512-00			RES.,FXD,COMP:5.1K OHM,5%,0.25W	01121	CB5125
R506	315-0203-00			RES.,FXD,COMP:20K OHM,5%,0.25W	01121	CB2035
R507	315-0512-00			RES.,FXD,COMP:5.1K OHM,5%,0.25W	01121	CB5125
R509	315-0102-00			RES.,FXD,COMP:1K OHM,5%,0.25W	01121	CB1025
R511	315-0681-00			RES.,FXD,COMP:680 OHM,5%,0.25W	01121	CB6815
R512	315-0681-00			RES.,FXD,COMP:680 OHM,5%,0.25W	01121	CB6815
R517	315-0752-00			RES.,FXD,COMP:7.5K OHM,5%,0.25W	01121	CB7525
R518	315-0752-00			RES.,FXD,COMP:7.5K OHM,5%,0.25W	01121	CB7525
R520	315-0752-00			RES.,FXD,COMP:7.5K OHM,5%,0.25W	01121	CB7525
R522	315-0103-00			RES.,FXD,COMP:10K OHM,5%,0.25W	01121	CB1035
R523	315-0154-00			RES.,FXD,COMP:150K OHM,5%,0.25W	01121	CB1545
R526	315-0154-00			RES.,FXD,COMP:150K OHM,5%,0.25W	01121	CB1545
R527	321-0335-00			RES.,FXD,FILM:30.1K OHM,1%,0.125W	75042	CEAT0-3012F
R530	315-0103-00			RES.,FXD,COMP:10K OHM,5%,0.25W	01121	CB1035
R531	315-0154-00			RES.,FXD,COMP:150K OHM,5%,0.25W	01121	CB1545
R534	315-0154-00			RES.,FXD,COMP:150K OHM,5%,0.25W	01121	CB1545
R538	315-0103-00			RES.,FXD,COMP:10K OHM,5%,0.25W	01121	CB1035
R539	315-0154-00			RES.,FXD,COMP:150K OHM,5%,0.25W	01121	CB1545
R541	315-0154-00			RES.,FXD,COMP:150K OHM,5%,0.25W	01121	CB1545
R544	315-0103-00			RES.,FXD,COMP:10K OHM,5%,0.25W	01121	CB1035
R546	315-0154-00			RES.,FXD,COMP:150K OHM,5%,0.25W	01121	CB1545

Electrical Parts List-7D12

Ckt No.	Tektronix Part No.	Serial/Model No.		Name & Description	Mfr Code	Mfr Part Number
		Eff	Dscont			
R548	315-0133-00			RES.,FXD,COMP:13K OHM,5%,0.25W	01121	CB1335
R553	315-0683-00			RES.,FXD,COMP:68K OHM,5%,0.25W	01121	CB6835
R557	315-0154-00			RES.,FXD,COMP:150K OHM,5%,0.25W	01121	CB1545
R578	301-0241-00			RES.,FXD,COMP:240 OHM,5%,0.50W	01121	EB2415
R581	315-0300-00			RES.,FXD,COMP:30 OHM,5%,0.25W	01121	CB3005
R585	315-0300-00			RES.,FXD,COMP:30 OHM,5%,0.25W	01121	CB3005
R587	315-0751-00			RES.,FXD,COMP:750 OHM,5%,0.25W	01121	CB7515
R588	315-0302-00			RES.,FXD,COMP:3K OHM,5%,0.25W	01121	CB3025
R591	315-0470-00			RES.,FXD,COMP:47 OHM,5%,0.25W	01121	CB4705
R597	315-0751-00			RES.,FXD,COMP:750 OHM,5%,0.25W	01121	CB7515
R598	315-0302-00			RES.,FXD,COMP:3K OHM,5%,0.25W	01121	CB3025
R601	315-0470-00			RES.,FXD,COMP:47 OHM,5%,0.25W	01121	CB4705
R611	315-0681-00			RES.,FXD,COMP:680 OHM,5%,0.25W	01121	CB6815
R612	321-0666-00			RES.,FXD,FILM:3.04K OHM,0.5%,0.125W	75042	CEAT2-3041D
R613	311-1225-00			RES.,VAR,NONWIR:2.5K OHM,20%,0.5W	73138	72PM-07-0-102K
R614	321-0668-00			RES.,FXD,FILM:4.63K OHM,0.5%,0.125W	75042	CEAT2-4631D
R616	315-0203-00			RES.,FXD,COMP:20K OHM,5%,0.25W	01121	CB2035
R619	315-0243-00			RES.,FXD,COMP:24K OHM,5%,0.25W	01121	CB2435
R621	308-0075-00			RES.,FXD,WW:100 OHM,5%,3W	91637	RS2B-B100R0J
R624	315-0162-00			RES.,FXD,COMP:1.6K OHM,5%,0.25W	01121	CB1625
R625	315-0361-00			RES.,FXD,COMP:360 OHM,5%,0.25W	01121	CB3615
R628	321-0685-00			RES.,FXD,FILM:30K OHM,0.5%,0.125W	75042	CEAT2-3002D
R629	321-0720-03			RES.,FXD,COMP:60K OHM,0.25%,0.125W	91637	MFF1816D60001C
R633	317-0200-00			RES.,FXD,COMP:20 OHM,5%,0.125W	01121	BB2005
R637	315-0301-00			RES.,FXD,COMP:300 OHM,5%,0.25W	01121	CB3015
R638	315-0302-00			RES.,FXD,COMP:3K OHM,5%,0.25W	01121	CB3025
R640	321-0653-00			RES.,FXD,FILM:102K OHM,0.5%,0.125W	91637	MFF1816D10202D
R641	321-0679-00			RES.,FXD,FILM:34K OHM,0.5%,0.125W	75042	CEAT2-3402D
R643	315-0243-00			RES.,FXD,COMP:24K OHM,5%,0.25W	01121	CB2435
R648	308-0075-00			RES.,FXD,WW:100 OHM,5%,3W	91637	RS2B-B100R0J
R650	317-0100-00			RES.,FXD,COMP:10 OHM,5%,0.125W	01121	BB1005
R652	315-0202-00			RES.,FXD,COMP:2K OHM,5%,0.25W	01121	CB2025
R660	315-0511-00			RES.,FXD,COMP:510 OHM,5%,0.25W	01121	CB5115
R663	315-0202-00			RES.,FXD,COMP:2K OHM,5%,0.25W	01121	CB2025
R667	303-0560-00			RES.,FXD,COMP:56 OHM,5%,1W	01121	GB5605
S110	105-0372-00			ACTUATOR,ASSY:ATTEN	80009	105-0372-00
S142	260-0723-00			SWITCH,SLIDE:DPDT,0.5A,125VAC	80009	260-0723-00
S165	260-1132-00			SWITCH,PUSH:GATE	80009	260-1132-00
S424 <sup>1</sup>	670-2175-00			SWITCH,PUSH BUTTON:MAN-EXT-AUTO	80009	670-2175-00
T125	120-0445-00			XFMR,TOROID:8 TURNS BIFILAR	80009	120-0445-00
T184	120-0487-00			XFMR,TOROID:5 TURNS BIFILAR	80009	120-0487-00
T324	120-0697-00			XFMR,TOROID:TWO 20 TURN WINDINGS	80009	120-0697-00
T326	120-0697-00			XFMR,TOROID:TWO 20 TURN WINDINGS	80009	120-0697-00
T348	120-0697-00			XFMR,TOROID:TWO 20 TURNS WINDINGS	80009	120-0697-00
T391	120-0697-00			XFMR,TOROID:TWO 20 TURN WINDINGS	80009	120-0697-00
T595	120-0849-00			XFMR,POWER:POT CORE	80009	120-0849-00
U124	156-0158-00			INTEGRATED CKT:DUAL OPERATIONAL AMPLIFIER	18324	S5558V
U148	155-0022-00			INTEGRATED CKT:ML,CHANNEL SWITCH	80009	155-0022-00
U248	156-0158-00			INTEGRATED CKT:DUAL OPERATIONAL AMPLIFIER	18324	S5558V
U260	156-0067-04			INTEGRATED CKT:OPERATIONAL AMPLIFIER,SEL	80009	156-0067-04
U276	156-0067-04			INTEGRATED CKT:OPERATIONAL AMPLIFIER,SEL	80009	156-0067-04
U283	156-0067-00			INTEGRATED CKT:OPERATIONAL AMPLIFIER	07263	UA741
U289	156-0109-00			INTEGRATED CKT:GAAS,LED,NPN,PHOTO XSTR	26483	MCT2
U301	156-0067-00			INTEGRATED CKT:OPERATIONAL AMPLIFIER	07263	UA741
U317	156-0039-00			INTEGRATED CKT:DUAL 15MHZ J-K M/S FF	04713	MC7473P
U342	156-0030-00			INTEGRATED CKT:QUAD 2-INPUT POS NAND GATE	01295	SN7400N
U351	156-0067-00			INTEGRATED CKT:OPERATIONAL AMPLIFIER	07263	UA741
U356	156-0067-02			INTEGRATED CKT:OPERATIONAL AMPLIFIER,SEL	80009	156-0067-02
U375	156-0067-00			INTEGRATED CKT:OPERATIONAL AMPLIFIER	07263	UA741

<sup>1</sup>See Mechanical Parts List for replacement parts.

Ckt No.	Tektronix Part No.	Serial/Model No.		Name & Description	Mfr Code	Mfr Part Number
		Eff	Dscont			
U380	156-0096-00			INTEGRATED CKT:VOLTAGE COMPARATOR	27014	LM311H
U402	156-0058-00			INTEGRATED CKT:HEX. INVERTER	04713	MC7404P
U436	156-0030-00			INTEGRATED CKT:QUAD 2-INPUT POS NAND GATE	01295	SN7400N
U440	156-0172-00			INTEGRATED CKT:DUAL RETRIGGERABLE SS	01295	SN74123N
U456	156-0039-00			INTEGRATED CKT:DUAL 15MHZ J-K M/S FF	04713	MC7473P
U458	156-0032-00			INTEGRATED CKT:4-BIT BINARY COUNTER	01295	SN7493N
U476	156-0030-00			INTEGRATED CKT:QUAD 2-INPUT POS NAND GATE	01295	SN7400N
U492	156-0043-00			INTEGRATED CKT:2-INPUT NOR GATE	01295	SN7402N
U495	156-0072-00			INTEGRATED CKT:MONOSTABLE MULTIVIBRATOR	12040	DM71421N
U500 <sup>1</sup>	155-0090-00			INTEGRATED CKT:MONOLITHIC,4 DECADE COUNTER	80009	155-0090-00
U509	156-0039-00			INTEGRATED CKT:DUAL 15MHZ J-K M/S FF	04713	MC7473P
U514	156-0040-00			INTEGRATED CKT:DUAL 2-BIT BISTABLE LATCH	01295	SN7475N
U618	156-0067-00			INTEGRATED CKT:OPERATIONAL AMPLIFIER	07263	UA741
U643	156-0067-00			INTEGRATED CKT:OPERATIONAL AMPLIFIER	07263	UA741
U659	156-0067-00			INTEGRATED CKT:OPERATIONAL AMPLIFIER	07263	UA741
VR245	152-0227-00			SEMICONV DEVICE:ZENER,6.2V,5%,0.4W	80009	152-0227-00
VR250	152-0168-00			SEMICONV DEVICE:ZENER,12V,5%,0.4W	04713	1N963B
VR264	152-0226-00			SEMICONV DEVICE:ZENER,5.1V,5%,0.4W	80009	152-0226-00
VR272	152-0226-00			SEMICONV DEVICE:ZENER,5.1V,5%,0.4W	80009	152-0226-00
VR281	152-0278-00			SEMICONV DEVICE:ZENER,3V,5%,0.4W	07910	1N4372A
VR282	152-0278-00			SEMICONV DEVICE:ZENER,3V,5%,0.4W	07910	1N4372A
VR284	152-0280-00			SEMICONV DEVICE:ZENER,6.2V,5%,0.4W	04713	1N753A
VR350	152-0317-00			SEMICONV DEVICE:ZENER,6.2V,5%,0.25W	81483	1N3497
VR354	152-0526-00			SEMICONV DEVICE:ZENER,6.35V,1%,7.5MA	80009	152-0526-00
VR357	152-0226-00			SEMICONV DEVICE:ZENER,5.1V,5%,0.4W	80009	152-0226-00
VR371	152-0227-00			SEMICONV DEVICE:ZENER,6.2V,5%,0.4W	80009	152-0227-00
VR577	152-0279-00			SEMICONV DEVICE:ZENER,5.1V,5%,0.4W	07910	1N751A
VR613	152-0123-00			SEMICONV DEVICE:ZENER,9V,5%,0.5W	80009	152-0123-00
VR619	152-0226-00			SEMICONV DEVICE:ZENER,5.1V,5%,0.4W	80009	152-0226-00
VR637	152-0508-00			SEMICONV DEVICE:ZENER,12.6V,5%,0.4W	80009	152-0508-00
VR645	152-0226-00			SEMICONV DEVICE:ZENER,5.1V,5%,0.4W	80009	152-0226-00
VR652	152-0226-00			SEMICONV DEVICE:ZENER,5.1V,5%,0.4W	80009	152-0226-00
Y449	158-0014-00			XTAL UNIT,QTZ:1000KC	80009	158-0014-00

<sup>1</sup>155-0090-02 may be used.



# DIAGRAMS AND CIRCUIT BOARD ILLUSTRATIONS

## Symbols and Reference Designators

Electrical components shown on the diagrams are in the following units unless noted otherwise:

- Capacitors = Values one or greater are in picofarads (pF).  
Values less than one are in microfarads ( $\mu$ F).
- Resistors = Ohms ( $\Omega$ ).

Symbols used on the diagrams are based on USA Standard Y32.2-1967.

Logic symbology is based on MIL-STD-806B in terms of positive logic. Logic symbols depict the logic function performed and may differ from the manufacturer's data.

The following prefix letters are used as reference designators to identify components or assemblies on the diagrams.

A	Assembly, separable or repairable (circuit board, etc.)	H	Heat dissipating device (heat sink, heat radiator, etc.)	RT	Thermistor
AT	Attenuator, fixed or variable	HR	Heater	S	Switch
B	Motor	HY	Hybrid circuit	T	Transformer
BT	Battery	J	Connector, stationary portion	TC	Thermocouple
C	Capacitor, fixed or variable	K	Relay	TP	Test point
CB	Circuit breaker	L	Inductor, fixed or variable	U	Assembly, inseparable or non-repairable (integrated circuit, etc.)
CR	Diode, signal or rectifier	LR	Inductor/resistor combination	V	Electron tube
DL	Delay line	M	Meter	VR	Voltage regulator (zener diode, etc.)
DS	Indicating device (lamp)	P	Connector, movable portion	Y	Crystal
E	Spark Gap	Q	Transistor or silicon-controlled rectifier	Z	Phase shifter
F	Fuse	R	Resistor, fixed or variable		
FL	Filter				

The following special symbols are used on the diagrams:

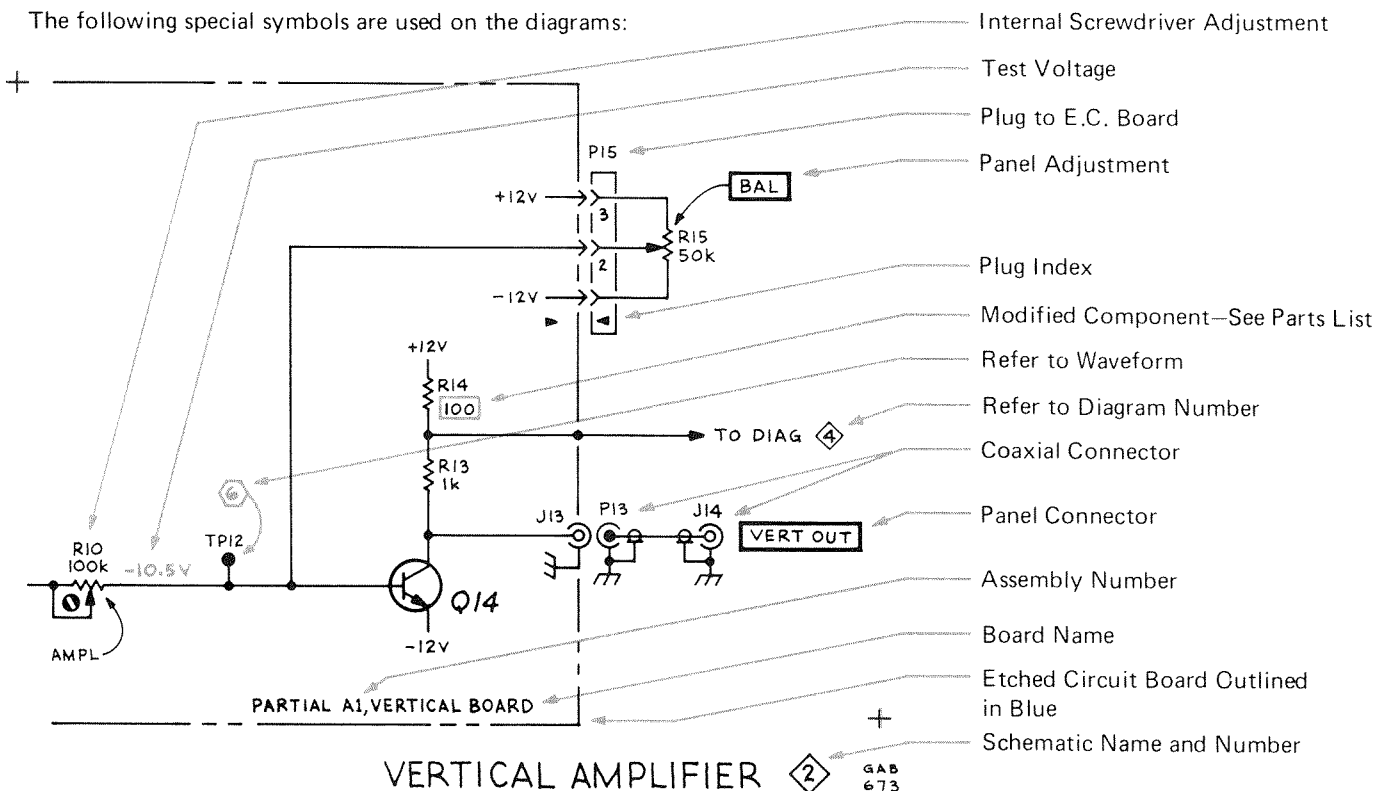

7D12 Service

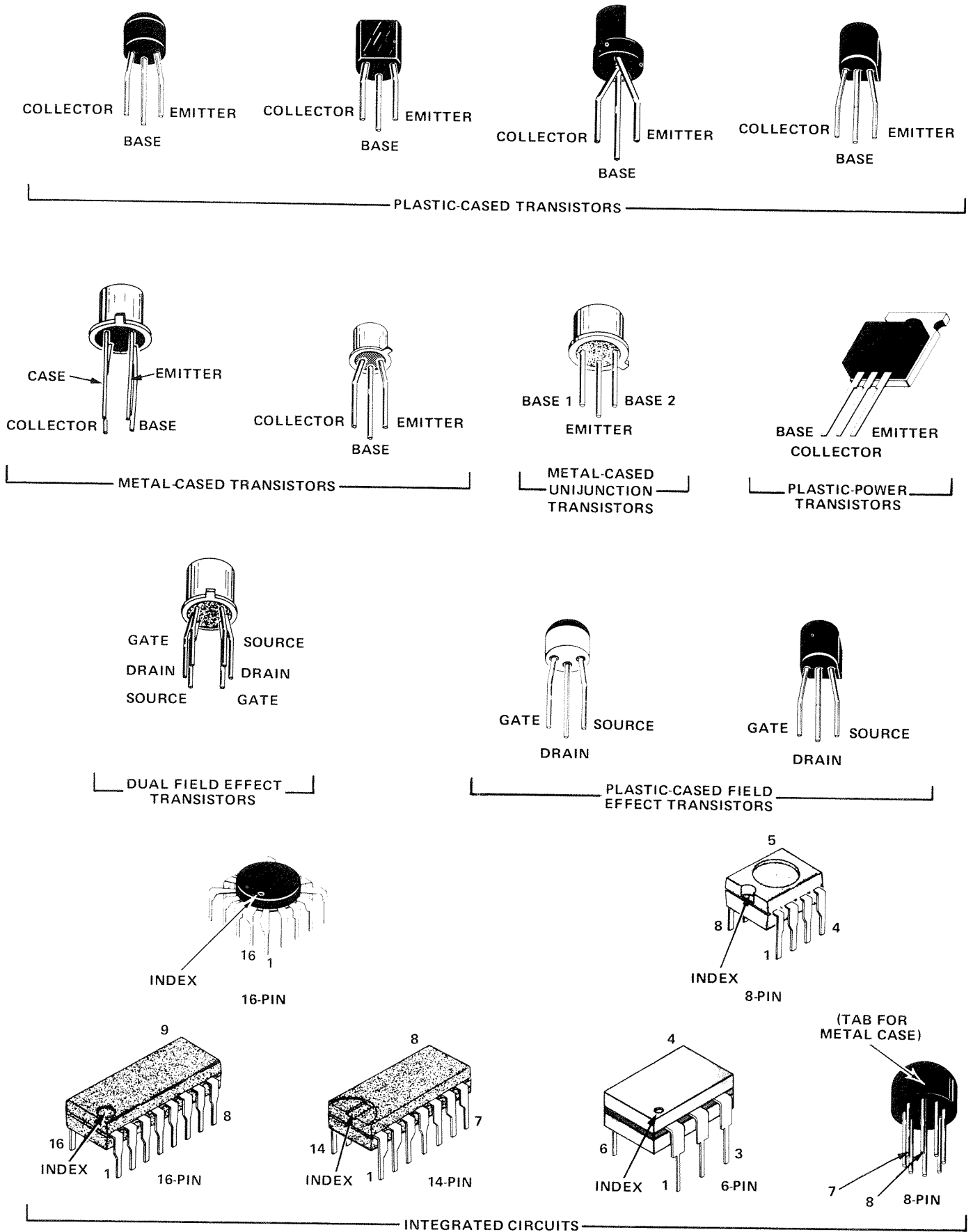
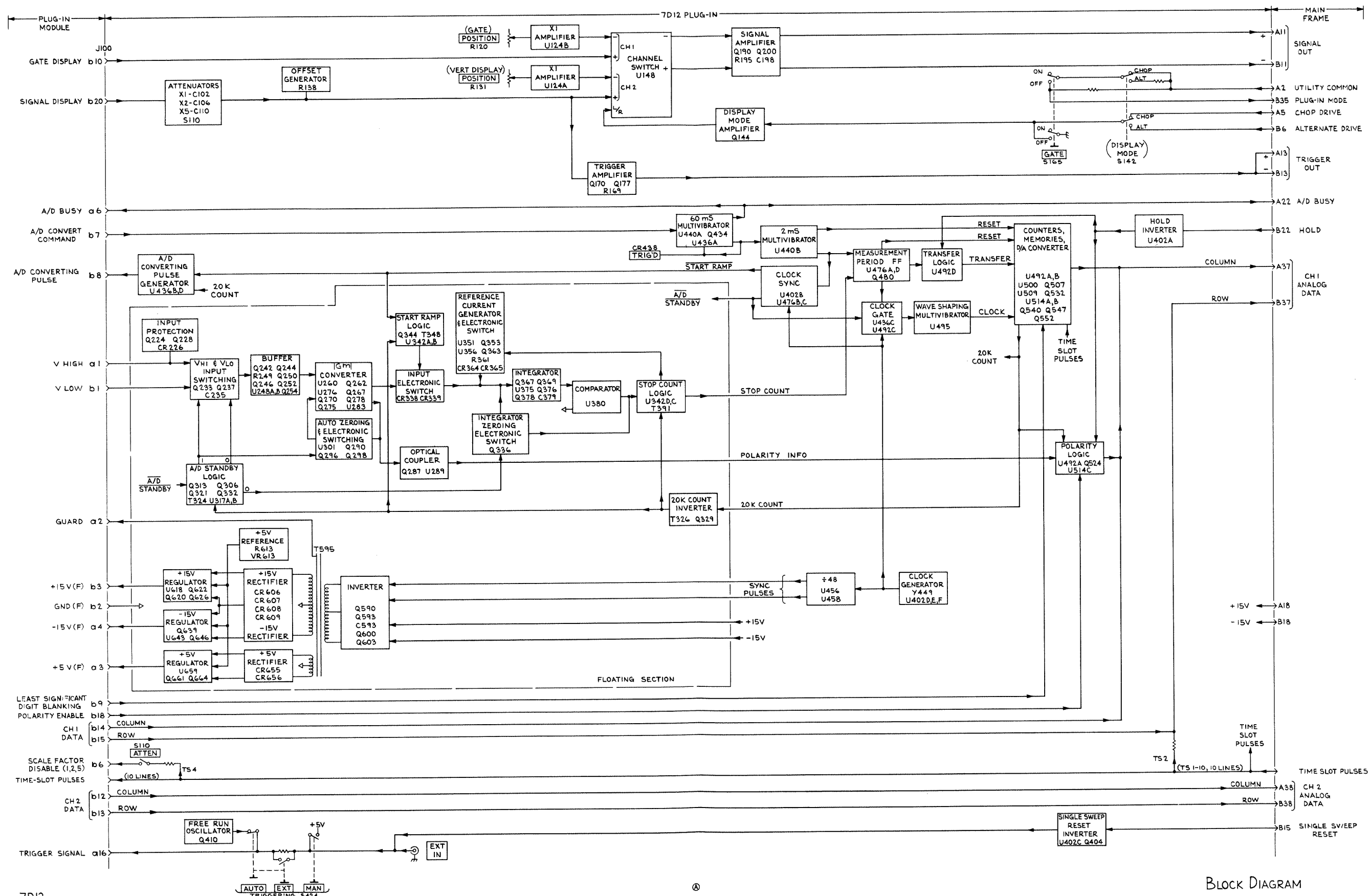

Fig. 6-1. Semiconductor lead configurations.



BLOCK DIAGRAM

7D12

BLOCK DIAGRAM

ASSEMBLY A1

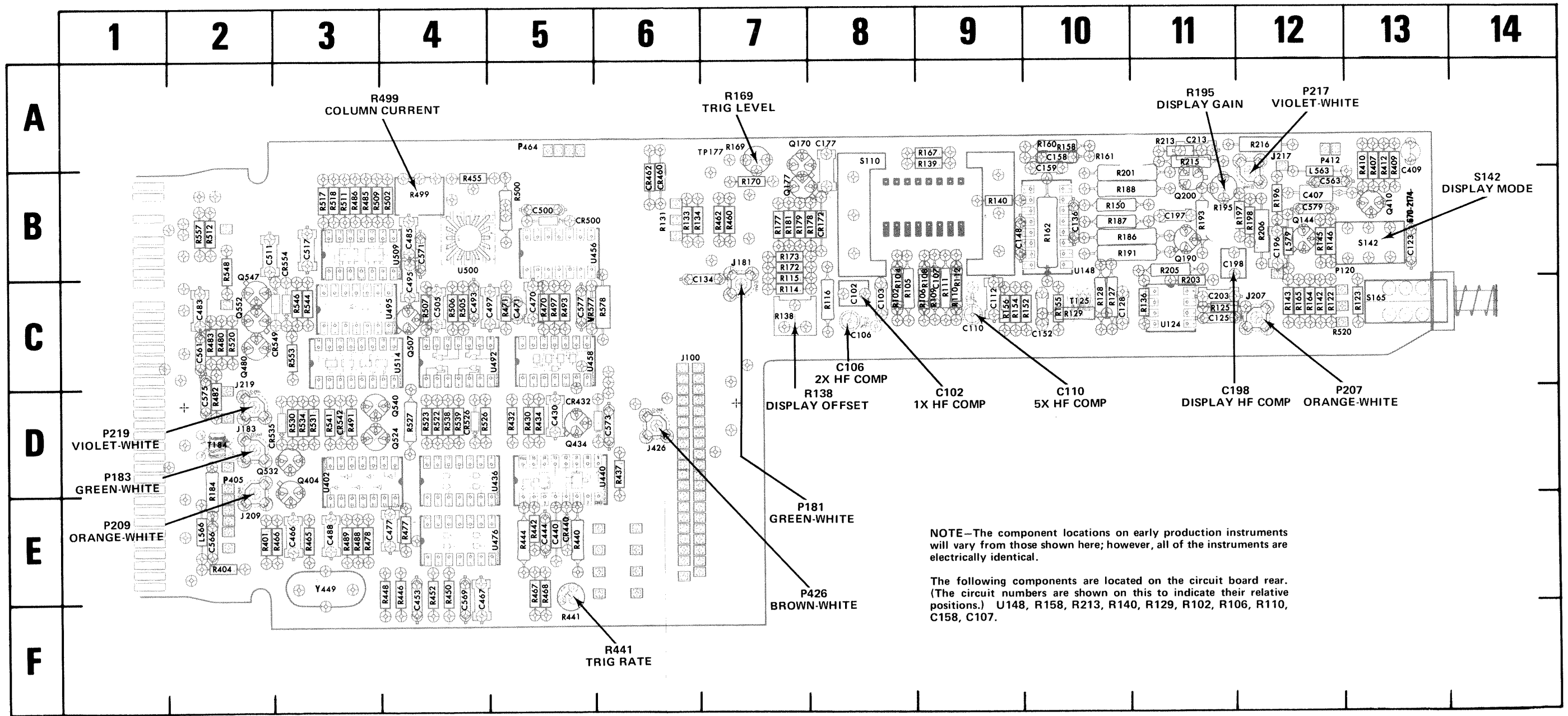

Fig. 6-2. (A1) Main board component locations.

CKT NO	GRID LOC	CKT NO	GRID LOC	CKT NO	GRID LOC	CKT NO	GRID LOC	CKT NO	GRID LOC	CKT NO	GRID LOC	CKT NO	GRID LOC	CKT NO	GRID LOC	CKT NO	GRID LOC	CKT NO	GRID LOC	CKT NO	GRID LOC	CKT NO	GRID LOC	CKT NO	GRID LOC				
C102	8C	C197	11B	C488	3E	CR172	8B	J217	12A	Q190	11B	R108	9C	R136	11C	R167	9A	R197	12B	R430	5D	R467	5E	R500	5B	R534	3D	TP177	7A
C103	8C	C198	11B	C493	5C	CR432	5D	J219	2C	Q200	11B	R109	9C	R138	7C	R169	7A	R198	12B	R432	5D	R468	5E	R502	4B	R538	4D		
C106	8C	C203	11C	C495	4C	CR440	5E	J426	6D	Q404	3D	R110	9C	R139	9A	R170	7B	R201	10B	R434	5D	R470	5C	R505	4C	R539	4D	U124	11C
C107	9C	C213	11A	C497	5C	CR460	6B			Q410	13B	R111	9C	R140	9B	R172	7B	R203	11C	R437	6D	R471	5C	R506	4C	R541	3D	U148	10B
C110	9C	C407	12B	C500	5B	CR462	6B			Q434	5D	R112	9C	R142	12C	R173	7B	R205	11B	R440	5E	R477	4E	R507	4C	R544	4D	U402	3D
C112	9C	C409	13B	C505	4C	CR500	5B	L563	12B	Q480	2C	R114	7C	R143	12C	R177	7B	R206	12B	R441	5F	R478	3E	R509	3B	R546	3C	U436	5D
C123	13B	C430	5D	C511	2B	CR526	4D	L566	2E	Q507	4C	R115	7C	R150	10B	R178	7B	R213	11A	R442	5E	R480	2C	R511	3B	R548	2B	U440	6D
C125	11C	C440	5E	C517	3B	CR535	2D	L579	12B	Q524	4D	R116	8C	R152	10C	R179	7B	R215	11A	R444	5E	R482	2D	R512	2B	R553	3C	U458	5C
C128	10C	C444	5E	C561	2C	CR542	3D			Q532	2D	R122	12C	R154	9C	R181	7B	R216	12A	R446	4E	R483	2C	R517	3B	R557	2B	U476	5E
C134	7B	C467	4E	C563	12B	CR549	3C	P120	13B	Q540	4D	R123	13C	R155	10C	R184	2D	R401	2E	R448	4E	R485	4B	R518	3B	R578	6C	U492	5C
C136	10B	C453	4E	C566	2E	CR554	3B	P405	2D	Q547	2B	R125	11C	R156	9C	R186	10B	R404	2E	R450	4E	R486	3B	R520	2C			U495	4C
C148	9B	C466	3E	C569	4E			P412	12A	Q552	2C	R127	10C	R158	10A	R187	10B	R407	13A	R452	4E	R488	3E	R522	4D	S110	8A	U500	4B
C152	10C	C470	5C	C571	4B	J100	6C	P464	5A			R128	10C	R160	10A	R188	10B	R409	13A	R455	4B	R489	3E	R523	4D	S142	13B	U509	4B
C158	10A	C471	5C	C573	6D	J181	7B			R102	8C	R129	10C	R161	10A	R191	10B	R410	13A	R460	7B	R491	3D	R526	4D	S165	13C	U514	4C
C159	10A	C477	4E	C575	2D	J183	2D	Q144	12B	R104	8C	R131	6B	R162	10B	R193	11B	R412	13A	R462	7B	R493	5C	R527	4D			U546	5B
C177	8A	C483	2C	C577	5C	J207	12C	Q170	7A	R105	8C	R133	6B	R164	12C	R195	11B	R415	12B	R465	3E	R497	5C	R530	3D	T125	10C	VR577	5C
C196	12B	C485	4B	C579	12B	J209	2E	Q177	7B	R106	9C	R134	6B	R165	12C	R196	12B	R416	12B	R466	2E	R499	4B	R531	3D	T184	2D	Y449	3E



# VOLTAGES AND WAVEFORMS

The voltages and waveforms shown on this diagram were obtained by using the recommended test equipment and test set-ups listed below, except as noted.

## RECOMMENDED TEST EQUIPMENT

ITEM	SPECIFICATIONS	RECOMMENDED TYPE
Oscilloscope system	Deflection factor 10 mV to 2 V/div. Input impedance 10 Megohms Frequency response dc to 25 MHz	a. Tektronix 7000-series oscilloscope equipped with readout, 7B-series Time-Base, 7A15A Amplifier, and a 1X probe. (7A13 Differential Comparator used in placed of 7A15A for calibrated offset voltages.)
Voltmeter (Non-loading digital multimeter)	Input impedance 10 Megohms Range (full scale) 2 V to 20 V	a. Tektronix 7D13 Digital Multimeter (oscilloscope system must have readout). b. Fairchild Model 7050, or equivalent.
Plug-in extender	Capable of extending the 7D12 from the oscilloscope plug-in compartment	a. Tektronix Part No. 067-0589-00 (rigid) or Tektronix Part No. 067-0616-00 (flexible).

## 7D12 AND 067-0700-00 CONTROL SETTINGS

VERTICAL DISPLAY ATTEN	1X
TRIGGERING	AUTO
GATE	ON
VERTICAL DISPLAY and GATE POSITION	Center traces on graticule
Readout Mode Switch	Out-atten readout check
Internal Display Mode Switch	Chop

## VOLTAGE CONDITIONS

Voltage measurements are taken with no signal applied and the trace centered on the graticule. The voltmeter common is connected to chassis ground. The 7D12 is connected to one of the vertical compartments of the oscilloscope mainframe through the plug-in extender. The 7D13, if used, is inserted into the other vertical compartment.

## WAVEFORM CONDITIONS

The 7D12 is connected to one of the vertical compartments of the oscilloscope mainframe through the plug-in extender. The amplifier plug-in, 7A15A or 7A13 is inserted into the other vertical compartment. A 1-kilohertz, 400 millivolt (200 mV, into 50  $\Omega$ ) signal is applied to the Vertical Display Direct Input connector and the Gate Waveform Direct Input connector of the 7D12 Calibration Fixture, 067-0700-00. The oscilloscope Trigger Source is set to trigger the time-base unit from the 7D12 output.

The waveform measurements are taken after the VERTICAL DISPLAY trace and the GATE trace are centered on the graticule (with no signal input).

If the 7A15A Amplifier plug-in is used, the input should be ac coupled.

Tolerances of the voltages and waveforms shown are  $\pm 20\%$ .

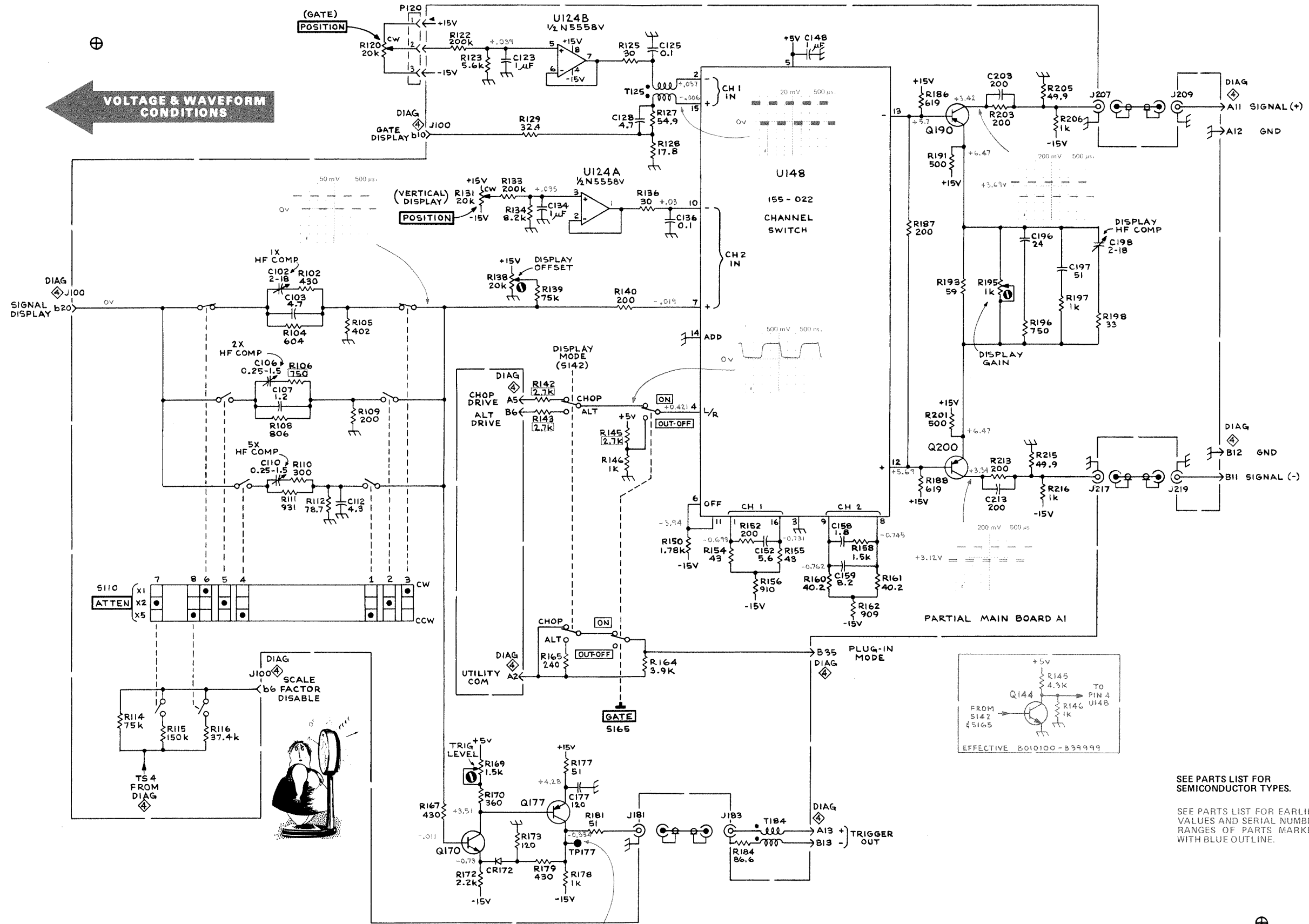

7D12

VERTICAL AMPLIFIER

SEE PARTS LIST FOR SEMICONDUCTOR TYPES.

SEE PARTS LIST FOR EARLIER VALUES AND SERIAL NUMBER RANGES OF PARTS MARKED WITH BLUE OUTLINE.

11-72

VERTICAL AMPLIFIER

1

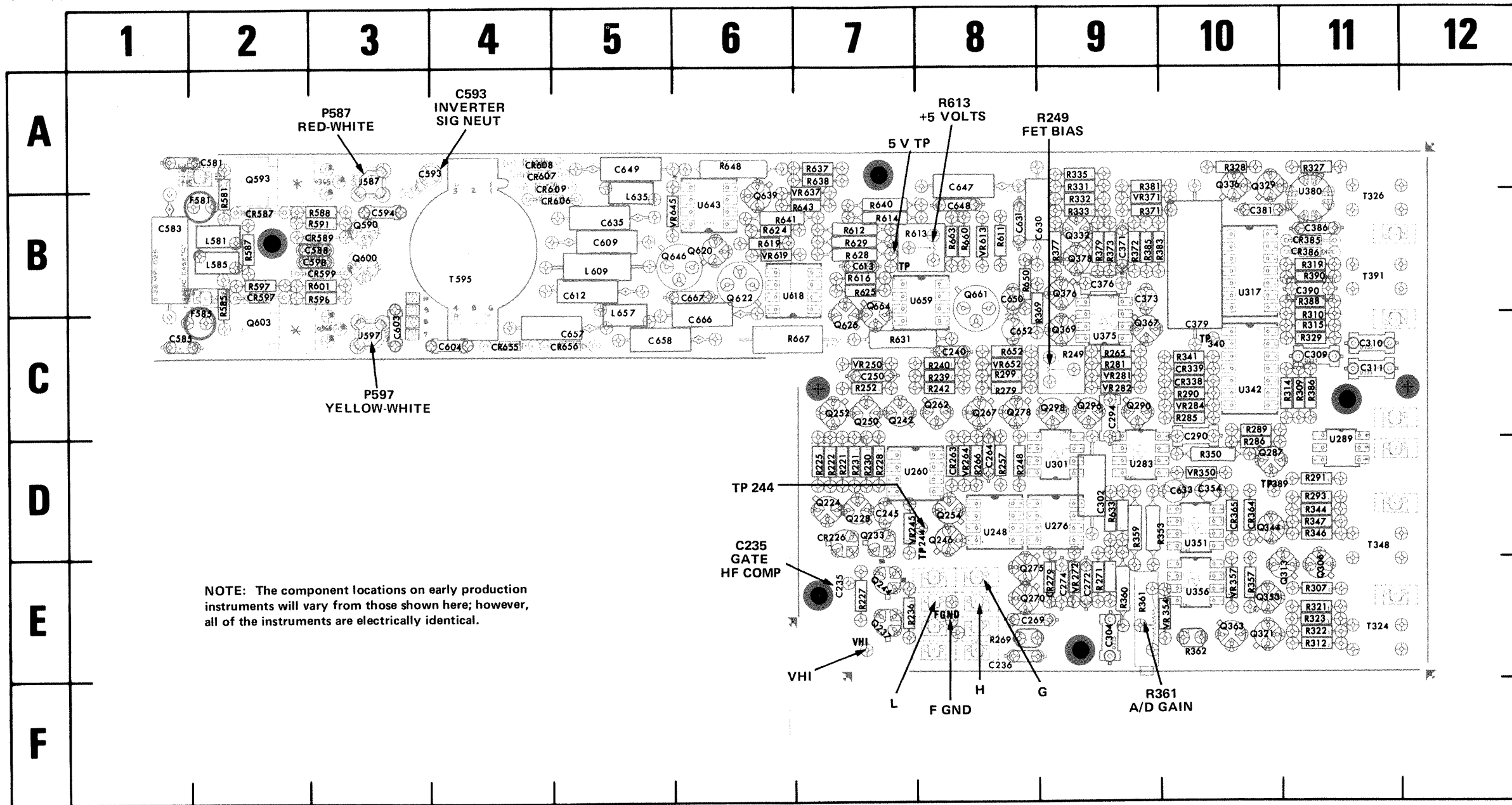

NOTE: The component locations on early production instruments will vary from those shown here; however, all of the instruments are electrically identical.

CKT NO	GRID LOC
R628	7B
R629	7B
R631	7C
R633	9D
R637	7A
R638	7A
R640	7B
R641	6B
R643	7B
R648	6A
R650	8B
R652	8C
R660	8B
R663	8B
R667	7C
T324	11E
T326	11B
T348	11D
T391	11B
T595	4B
TP224	8D
TP340	10C
TP389	10D
U248	8D
U260	8D
U276	9D
U283	9D
U289	11D
U301	9D
U317	10B
U342	10C
U351	10D
U356	10E
U375	9C
U380	11A
U618	7B
U643	6B
U659	8B
VR245	7D
VR250	7C
VR264	8D
VR272	9E
VR272	9E
VR281	9C
VR282	9C
VR284	10C
VR350	10D
VR354	10E
VR357	10E
VR613	8B
VR619	6B
VR637	7A
VR645	6B
VR652	8C

Fig. 6-3. (A2) Floating board component locations.

CKT NO	GRID LOC	CKT NO	GRID LOC	CKT NO	GRID LOC	CKT NO	GRID LOC	CKT NO	GRID LOC	CKT NO	GRID LOC	CKT NO	GRID LOC	CKT NO	GRID LOC	CKT NO	GRID LOC	CKT NO	GRID LOC	CKT NO	GRID LOC		
C235	7E	C373	9B	C613	7B	CR279	9E	F581	2B	Q244	7E	Q329	10A	Q626	7C	R252	7C	R310	11C	R344	11D	R553	9D
C236	8E	C376	9B	C630	8B	CR338	10C	F585	2B	Q246	8D	Q332	9B	Q646	6B	R257	8D	R312	11E	R346	11D	R581	2B
C240	8C	C379	10C	C631	8B	CR339	10C			Q250	7C	Q336	10A	Q661	8C	R265	9C	R314	11C	R347	11D	R585	2B
C245	7D	C381	10B	C633	10D	CR364	10D	J587	3A	Q252	7C	Q344	10D	Q664	7B	R266	8D	R315	11C	R350	10D	R588	3B
C250	7C	C386	11B	C635	5B	CR365	10D	J597	3C	Q254	8D	Q353	10E			R269	8E	R319	11B	R357	10E	R587	2B
C264	8D	C390	11B	C647	8A	CR385	11B			Q262	8C	Q363	10E	R221	7D	R271	9E	R321	11E	R359	9D	R591	3B
C269	8E	C581	2A	C648	8B	CR386	11B	L581	2B	Q267	8C	Q367	9C	R222	7D	R279	8C	R322	11E	R360	9E	R596	3B
C272	9E	C385	1B	C649	5A	CR587	2B	L585	2B	Q268	8C	Q369	9C	R225	7D	R281	9C	R323	11E	R361	9E	R597	2B
C274	9E	C585	1C	C650	8B	CR589	3B	L609	5B	Q270	8E	C376	9B	R227	7E	R285	10C	R326	7E	R362	10E	R601	3B
C290	10D	C588	3B	C652	8C	CR597	2B	L635	5B	Q275	8E	Q378	9B	R228	7D	R286	10D	R327	11A	R369	9B	R611	8B
C294	9C	C593	4A	C657	5C	CR599	3B	L657	5B	Q287	10D	Q590	3B	R230	7D	R289	10C	R328	10A	R371	9B	R612	7B
C302	9D	C504	3B	C658	5C	CR606	4B			Q290	9C	Q593	2A	R231	7D	R290	10C	R329	11C	R377	9B	R613	8B
C304	9E	C598	3B	C666	6C	CR607	4A	Q224	7D	Q296	9C	Q600	3B	R239	8C	R291	11D	R331	9A	R381	9A	R614	7B
C309	11C	C603	3C	C667	6B	CR608	4A	Q228	7D	Q298	9C	Q603	2C	R240	8C	R293	11D	R332	9B	R383	10B	R616	7B
C310	11C	C604	4C			CR609	4A	Q233	7D	Q306	11E	Q620	6B	R242	8C	R299	8C	R333	9B	R386	11C	R619	6B
C311	11C	C609	5B	CR226	7D	CR655	4C	Q237	7E	Q313	10E	Q622	6B	R248	8D	R307	11E	R335	9A	R388	11B	R624	6B
C354	10D	C612	5B	CR263	8D	CR656	5C	Q242	7C	Q321	10E	Q639	6A	R249	9C	R309	11C	R341	10C	R390	11B	R625	7B

ASSEMBLY A2

# VOLTAGES AND WAVEFORMS

The voltages and waveforms shown on this diagram were obtained by using the recommended test equipment and test set-ups listed below, except as noted.

## RECOMMENDED TEST EQUIPMENT

ITEM	SPECIFICATIONS	RECOMMENDED TYPE
Oscilloscope system	Deflection factor 10 mV to 2 V/div. Input impedance 10 Megohms Frequency response dc to 25 MHz	a. Tektronix 7000-series oscilloscope equipped with readout, 7B-series Time-Base, 7A15A Amplifier, and a 1X probe. (7A13 Differential Comparator used in place of 7A15A for calibrated offset voltages.)
Voltmeter (Non-loading digital multimeter)	Input impedance 10 Megohms Range (full scale) 2 V to 20 V	a. Tektronix 7D13 Digital Multimeter (oscilloscope system must have readout). b. Fairchild Model 7050, or equivalent.
Plug-in extender	Capable of extending the 7D12 from the oscilloscope plug-in compartment	a. Tektronix Part No. 067-0589-00 (rigid) or Tektronix Part No. 067-0616-00 (flexible).

## 7D12 AND 067-0700-00 CONTROL SETTINGS

VERTICAL DISPLAY ATTEN	1X
TRIGGERING	AUTO
GATE	OUT-OFF
VERTICAL DISPLAY POSITION	Center trace on graticule
Readout Mode Switch	Out-atten readout check
Internal Display Mode Switch	Chop

## VOLTAGE CONDITIONS

Voltage measurements are taken with no signal applied and the trace centered on the graticule. The voltmeter common is connected to floating ground. The 7D12 is connected to one of the vertical compartments of the oscilloscope mainframe through the plug-in extender. The 7D13, if used, is inserted into the other vertical compartment.

## WAVEFORM CONDITIONS

The 7D12 is connected to one of the vertical compartments of the oscilloscope mainframe through the plug-in extender. The amplifier plug-in, 7A15A or 7A13 is inserted into the other vertical compartment. A 1-kilohertz, 4 volt (400 mV, into 50  $\Omega$ ) signal is applied to the A/D DIRECT INPUT connectors of the 7D12 Calibration Fixture, 067-0700-00. The oscilloscope Trigger Source is set to trigger the time-base unit from the 7D12 output.

The 1X probe ground strap is connected to the floating ground (FGND) test point.

If the 7A15A Amplifier plug-in is used, the input should be ac coupled.

Tolerances of the voltages and waveforms shown are  $\pm 20\%$ .

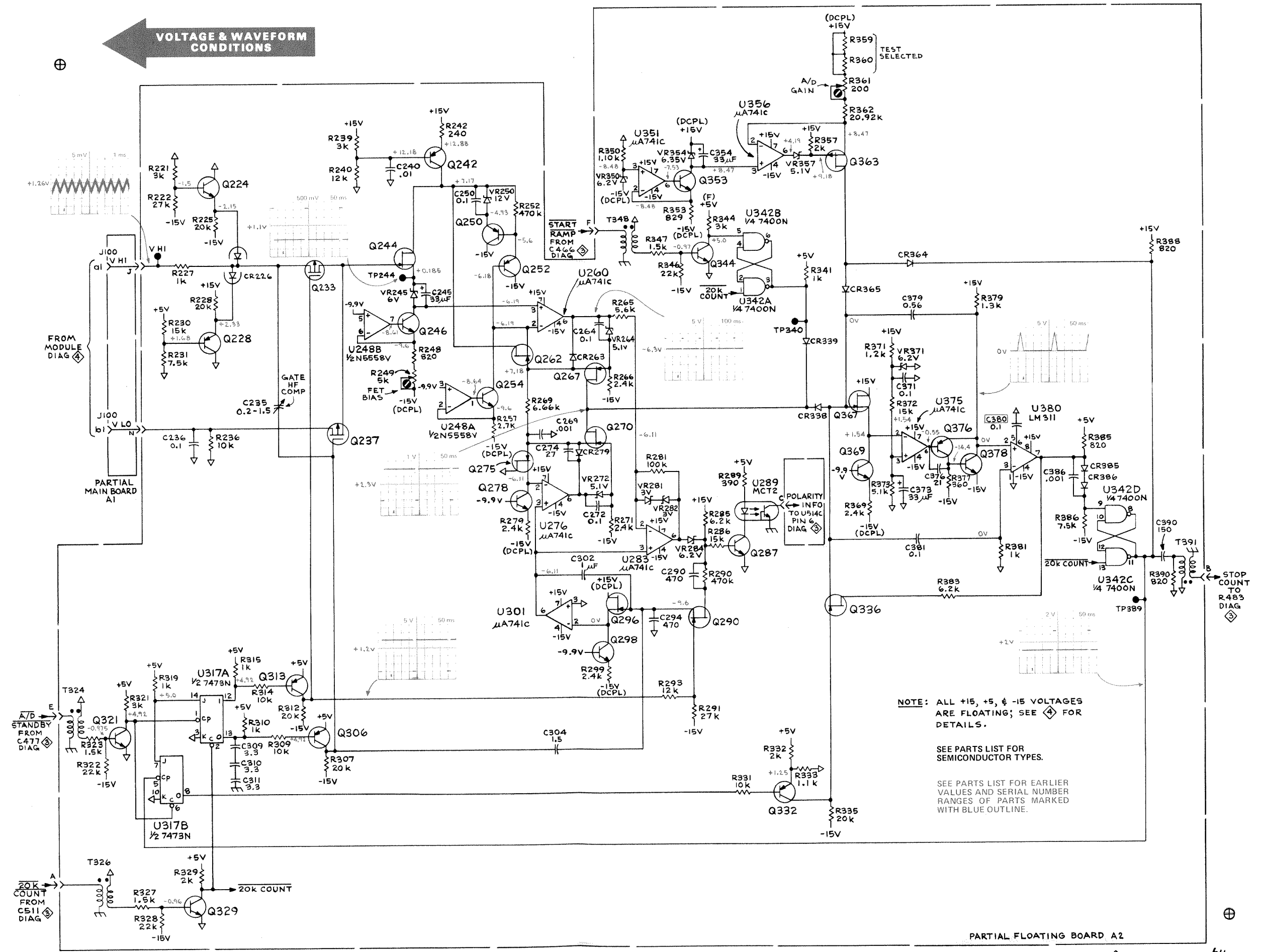

VOLTAGE & WAVEFORM CONDITIONS

NOTE: ALL +15, +5, & -15 VOLTAGES ARE FLOATING; SEE [4] FOR DETAILS.

SEE PARTS LIST FOR SEMICONDUCTOR TYPES.

SEE PARTS LIST FOR EARLIER VALUES AND SERIAL NUMBER RANGES OF PARTS MARKED WITH BLUE OUTLINE.

PARTIAL FLOATING BOARD A2

4 1/2 DIGIT A/D CONVERTER [2]

7D12

11272

4 1/2 DIGIT A/D CONVERTER [2]

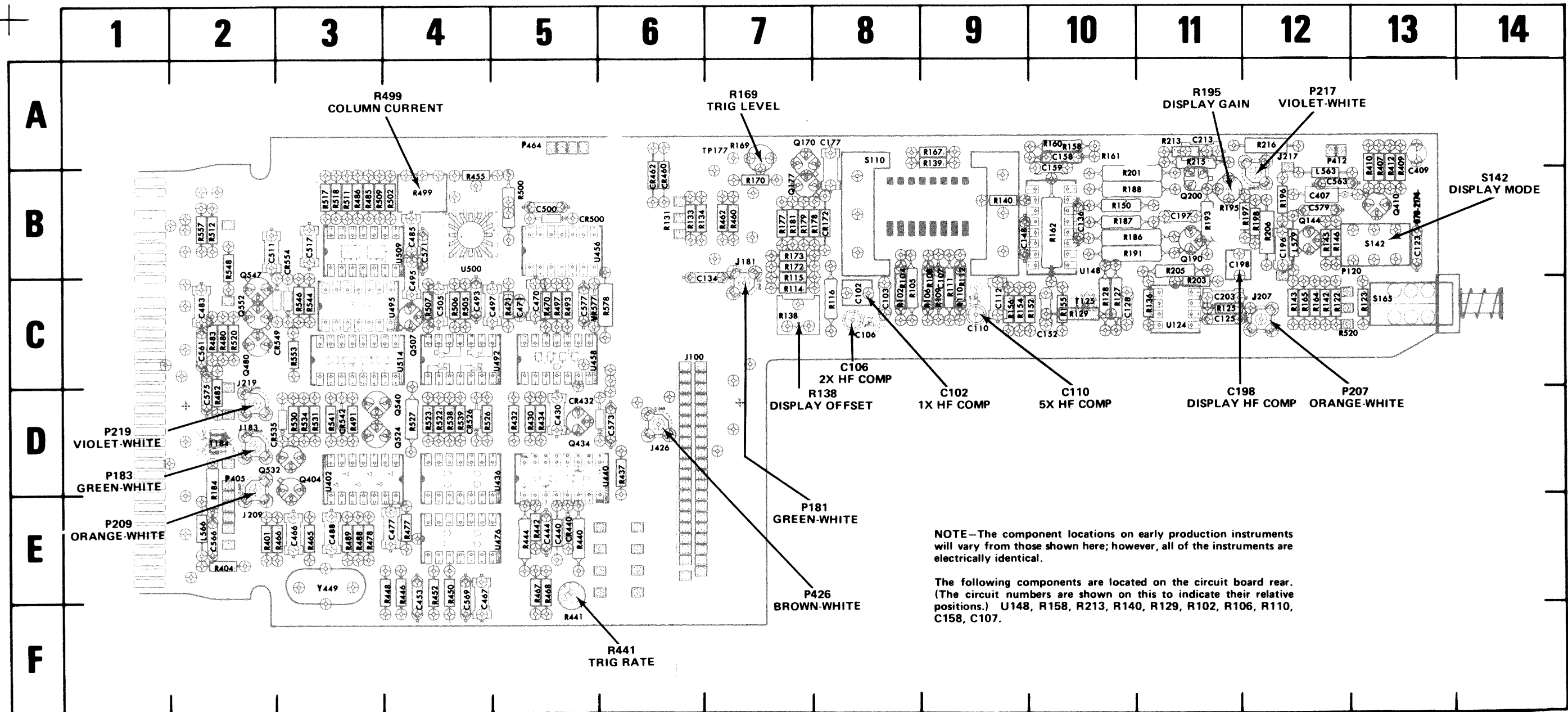

Fig. 6-4. (A1) Main board component locations.

CKT NO	GRID LOC	CKT NO	GRID LOC	CKT NO	GRID LOC	CKT NO	GRID LOC	CKT NO	GRID LOC	CKT NO	GRID LOC	CKT NO	GRID LOC	CKT NO	GRID LOC	CKT NO	GRID LOC	CKT NO	GRID LOC	CKT NO	GRID LOC	CKT NO	GRID LOC	CKT NO	GRID LOC				
C102	8C	C197	11B	C488	3E	CR172	8B	J217	12A	Q190	11B	R108	9C	R136	11C	R167	9A	R197	12B	R430	5D	R467	5E	R500	5B	R534	3D	TP177	7A
C103	8C	C198	11B	C493	5C	CR432	5D	J219	2C	Q200	11B	R109	9C	R138	7C	R169	7A	R198	12B	R432	5D	R468	5E	R502	4B	R538	4D		
C106	8C	C203	11C	C495	4C	CR440	5E	J426	6D	Q404	3D	R110	9C	R139	9A	R170	7B	R201	10B	R434	5D	R470	5C	R505	4C	R539	4D	U124	11C
C107	9C	C213	11A	C497	5C	CR460	6B			Q410	13B	R111	9C	R140	9B	R172	7B	R203	11C	R437	6D	R471	5C	R506	4C	R541	3D	U148	10B
C110	9C	C407	12B	C500	5B	CR462	6B			Q434	5D	R112	9C	R142	12C	R173	7B	R205	11B	R440	5E	R477	4E	R507	4C	R544	3D	U402	3D
C112	9C	C409	13B	C505	4C	CR500	5B	L563	12B	Q480	2C	R114	7C	R143	12C	R177	7B	R206	12B	R441	5F	R478	3E	R509	3B	R546	3C	U436	5D
C123	13B	C430	5D	C511	2B	CR526	4D	L566	2E	Q507	4C	R115	7C	R150	10B	R178	7B	R213	11A	R442	5E	R480	2C	R511	3B	R548	2B	U440	6D
C125	11C	C440	5E	C517	3B	CR535	2D	L579	12B	Q524	4D	R116	8C	R152	10C	R179	7B	R215	11A	R444	5E	R482	2D	R512	2B	R553	3C	U458	5C
C128	10C	C444	5E	C561	2C	CR542	3D			Q532	2D	R122	12C	R154	9C	R181	7B	R216	12A	R446	4E	R483	2C	R517	3B	R557	2B	U476	5E
C134	7B	C467	4E	C563	12B	CR549	3C	P120	13B	Q540	4D	R123	13C	R155	10C	R184	2D	R401	2E	R448	4E	R485	4B	R518	3B	R578	6C	U492	5C
C136	10B	C453	4E	C566	2E	CR554	3B	P405	2D	Q547	2B	R125	11C	R156	9C	R186	10B	R404	2E	R450	4E	R486	3B	R520	2C			U495	4C
C148	9B	C466	3E	C569	4E			P412	12A	Q552	2C	R127	10C	R158	10A	R187	10B	R407	13A	R452	4E	R488	3E	R522	4D	S110	8A	U500	4B
C152	10C	C470	5C	C571	4B	J100	6C	P464	5A			R128	10C	R160	10A	R188	10B	R409	13A	R455	4B	R489	3E	R523	4D	S142	13B	U509	4B
C158	10A	C471	5C	C573	6D	J181	7B			R102	8C	R129	10C	R161	10A	R191	10B	R410	13A	R460	7B	R491	3D	R526	4D	S165	13C	U514	4C
C159	10A	C477	4E	C575	2D	J183	2D	Q144	12B	R104	8C	R131	6B	R162	10B	R193	11B	R412	13A	R462	7B	R493	5C	R527	4D			U546	5B
C177	8A	C483	2C	C577	5C	J207	12C	Q170	7A	R105	8C	R133	6B	R164	12C	R195	11B	R415	12B	R465	3E	R497	5C	R530	3D	T125	10C	VR577	5C
C196	12B	C485	4B	C579	12B	J209	2E	Q177	7B	R106	9C	R134	6B	R165	12C	R196	12B	R416	12B	R466	2E	R499	4B	R531	3D	T184	2D	Y449	3E

ASSEMBLIES A1 & A3

4

ODE

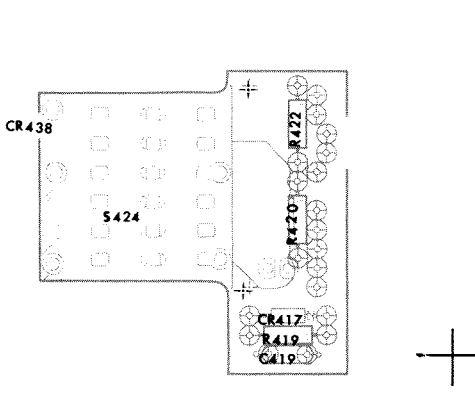

Fig. 6-5. (A3) Triggering switch board component locations.

Ⓐ

CKT NO	GRID LOC
TP177	7A
U124	11C
U148	10B
U402	3D
U436	5D
U440	6D
U458	5C
U476	5E
U492	5C
U495	4C
U500	4B
U509	4B
U514	4C
U546	5B
VR577	5C
Y449	3E

Ⓐ

# VOLTAGES AND WAVEFORMS

The voltages and waveforms shown on this diagram were obtained by using the recommended test equipment and test set-ups listed below, except as noted.

## RECOMMENDED TEST EQUIPMENT

ITEM	SPECIFICATIONS	RECOMMENDED TYPE
Oscilloscope system	Deflection factor 10 mV to 2 V/div. Input impedance 10 Megohms Frequency response dc to 25 MHz	a. Tektronix 7000-series oscilloscope equipped with readout, 7B-series Time-Base, 7A15A Amplifier, and a 1X probe. (7A13 Differential Comparator used in place of 7A15A for calibrated offset voltages.)
Voltmeter (Non-loading digital multimeter)	Input impedance 10 Megohms Range (full scale) 2 V to 20 V	a. Tektronix 7D13 Digital Multimeter (oscilloscope system must have readout). b. Fairchild Model 7050, or equivalent.
Plug-in extender	Capable of extending the 7D12 from the oscilloscope plug-in compartment	a. Tektronix Part No. 067-0589-00 (rigid) or Tektronix Part No. 067-0616-00 (flexible).

## 7D12 AND 067-0700-00 CONTROL SETTINGS

VERTICAL DISPLAY ATTEN	1X
TRIGGERING	AUTO
GATE	OUT-OFF
VERTICAL DISPLAY POSITION	Center trace on graticule
Readout Mode Switch	Out-atten readout check
Internal Display Mode Switch	Chop

## VOLTAGE CONDITIONS

Voltage measurements are taken with no signal applied and the trace centered on the graticule. The voltmeter common is connected to chassis ground. The 7D12 is connected to one of the vertical compartments of the oscilloscope mainframe through the plug-in extender. The 7D13, if used, is inserted into the other vertical compartment.

## WAVEFORM CONDITIONS

The 7D12 is connected to one of the vertical compartments of the oscilloscope mainframe through the plug-in extender. The amplifier plug-in, 7A15A or 7A13 is inserted into the other vertical compartment. A 1-kilohertz, 4 volt (400 mV, into 50  $\Omega$ ) signal is applied to the A/D DIRECT INPUT connectors of the 7D12 Calibration Fixture, 067-0700-00. The oscilloscope Trigger Source is set to trigger the time-base unit from the 7D12 output.

If the 7A15A Amplifier plug-in is used, the input should be ac coupled.

Tolerances of the voltages and waveforms shown are  $\pm 20\%$ .



VOLTAGE & WAVEFORM CONDITIONS

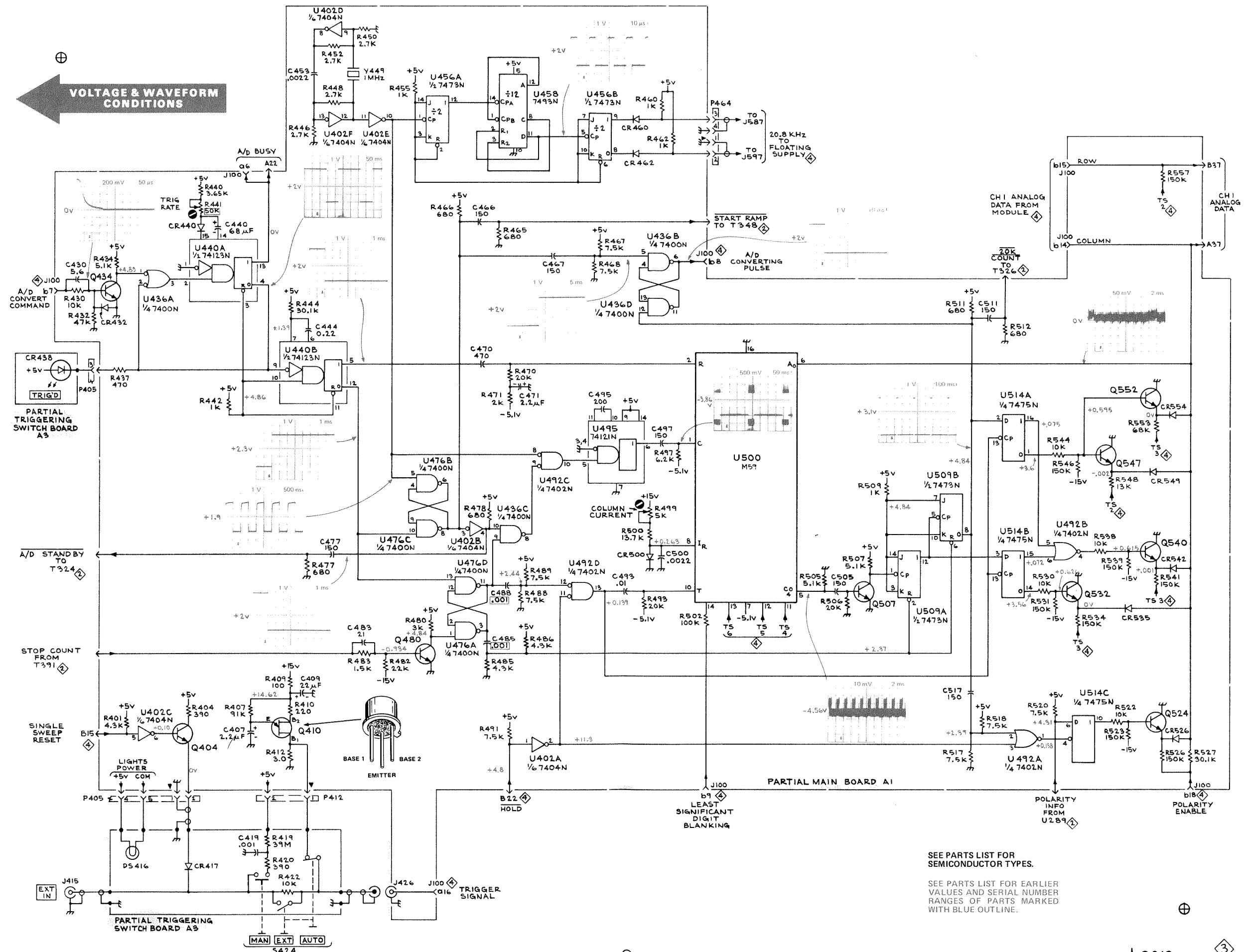

SEE PARTS LIST FOR SEMICONDUCTOR TYPES.

SEE PARTS LIST FOR EARLIER VALUES AND SERIAL NUMBER RANGES OF PARTS MARKED WITH BLUE OUTLINE.

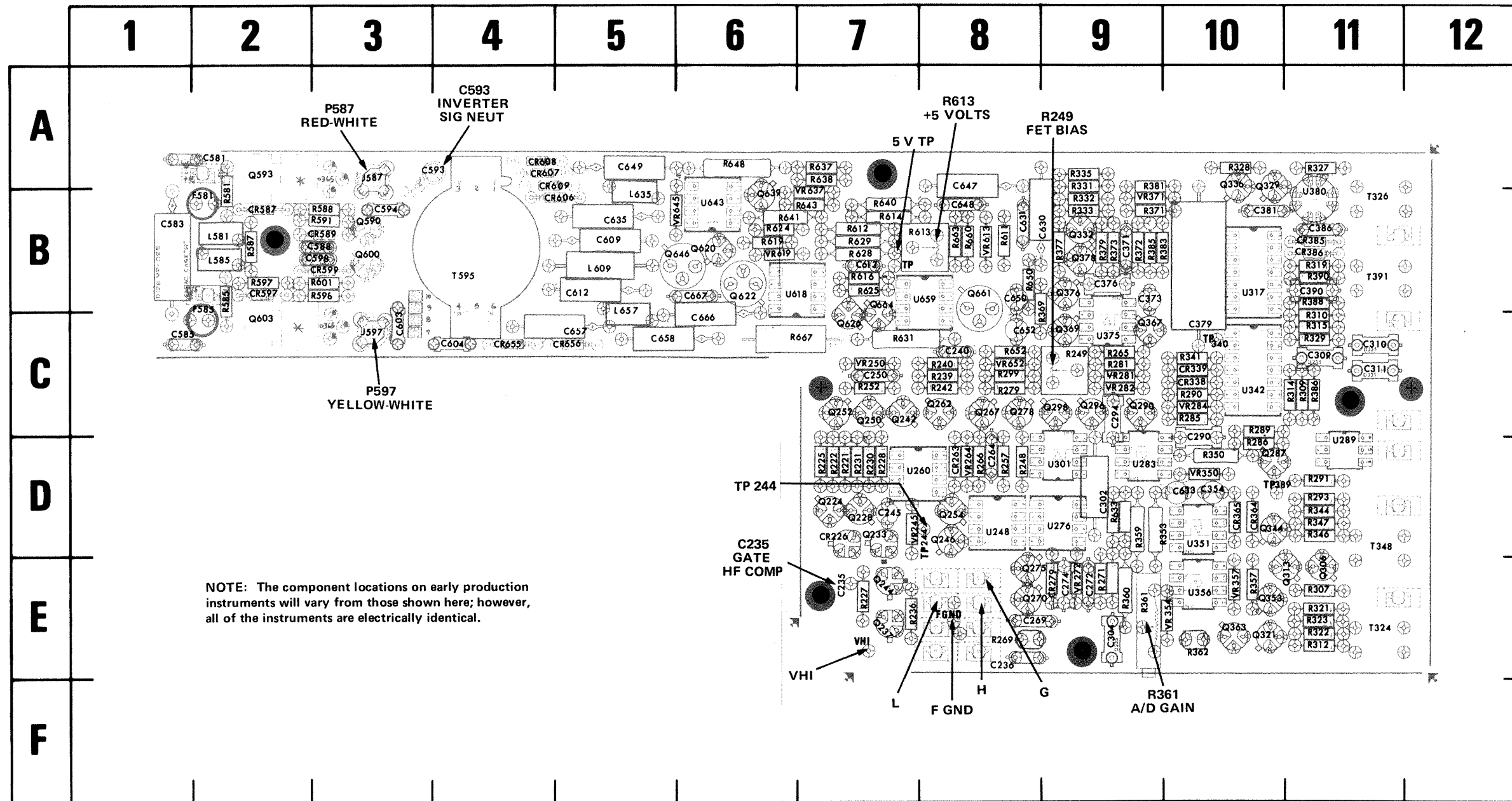

CKT NO	GRID LOC
R628	7B
R629	7B
R631	7C
R633	9D
R637	7A
R638	7A
R640	7B
R641	6B
R643	7B
R648	6A
R650	8B
R652	8C
R660	8B
R663	8B
R667	7C
T324	11E
T326	11B
T348	11D
T391	11B
T595	4B
TP224	8D
TP340	10C
TP389	10D
U248	8D
U260	8D
U276	9D
U283	9D
U289	11D
U301	9D
U317	10B
U342	10C
U351	10D
U356	10E
U375	9C
U380	11A
U618	7B
U643	6B
U659	8B
VR245	7D
VR250	7C
VR264	8D
VR272	9E
VR272	9E
VR281	9C
VR282	9C
VR284	10C
VR350	10D
VR354	10E
VR371	9B
VR371	9B
VR613	8B
VR619	6B
VR637	7A
VR645	6B
VR652	8C

Fig. 6-6. (A2) Floating board component locations.

CKT NO	GRID LOC	CKT NO	GRID LOC	CKT NO	GRID LOC	CKT NO	GRID LOC	CKT NO	GRID LOC	CKT NO	GRID LOC	CKT NO	GRID LOC	CKT NO	GRID LOC	CKT NO	GRID LOC	CKT NO	GRID LOC	CKT NO	GRID LOC		
C235	7E	C373	9B	C613	7B	CR279	9E	F581	2B	Q244	7E	Q329	10A	Q626	7C	R252	7C	R310	11C	R344	11D	R553	9D
C236	8E	C376	9B	C630	8B	CR338	10C	F585	2B	Q246	8D	Q332	9B	Q646	6B	R257	8D	R312	11E	R346	11D	R581	2B
C240	8C	C379	10C	C631	8B	CR339	10C			Q250	7C	Q336	10A	Q661	8C	R265	9C	R314	11C	R347	11D	R585	2B
C245	7D	C381	10B	C633	10D	CR364	10D	J587	3A	Q252	7C	Q344	10D	Q664	7B	R266	8D	R315	11C	R350	10D	R588	3B
C250	7C	C386	11B	C635	5B	CR365	10D	J597	3C	Q254	8D	Q353	10E			R269	8E	R319	11B	R357	10E	R587	2B
C264	8D	C390	11B	C647	8A	CR385	11B			Q262	8C	Q363	10E	R221	7D	R271	9E	R321	11E	R359	9D	R591	3B
C269	8E	C581	2A	C648	8B	CR386	11B	L581	2B	Q267	8C	Q367	9C	R222	7D	R279	8C	R322	11E	R360	9E	R596	3B
C272	9E	C385	1B	C649	5A	CR587	2B	L585	2B	Q268	8C	Q369	9C	R225	7D	R281	9C	R323	11E	R361	9E	R597	2B
C274	9E	C585	1C	C650	8B	CR589	3B	L609	5B	Q270	8E	C376	9B	R227	7E	R285	10C	R326	7E	R362	10E	R601	3B
C290	10D	C588	3B	C652	8C	CR597	2B	L635	5B	Q275	8E	Q378	9B	R228	7D	R286	10D	R327	11A	R369	9B	R611	8B
C294	9C	C593	4A	C657	5C	CR599	3B	L657	5B	Q287	10D	Q590	3B	R230	7D	R289	10C	R328	10A	R371	9B	R612	7B
C302	9D	C504	3B	C658	5C	CR606	4B			Q290	9C	Q593	2A	R231	7D	R290	10C	R329	11C	R377	9B	R613	8B
C304	9E	C598	3B	C666	6C	CR607	4A	Q224	7D	Q296	9C	Q600	3B	R239	8C	R291	11D	R331	9A	R381	9A	R614	7B
C309	11C	C603	3C	C667	6B	CR608	4A	Q228	7D	Q298	9C	Q603	2C	R240	8C	R293	11D	R332	9B	R383	10B	R616	7B
C310	11C	C604	4C			CR609	4A	Q233	7D	Q306	11E	Q620	6B	R242	8C	R299	8C	R333	9B	R386	11C	R619	6B
C311	11C	C609	5B	CR226	7D	CR655	4C	Q237	7E	Q313	10E	Q622	6B	R248	8D	R307	11E	R335	9A	R388	11B	R624	6B
C354	10D	C612	5B	CR263	8D	CR656	5C	Q242	7C	Q321	10E	Q639	6A	R249	9C	R309	11C	R341	10C	R390	11B	R625	7B

# VOLTAGES AND WAVEFORMS

The voltages and waveforms shown on this diagram were obtained by using the recommended test equipment and test set-ups listed below, except as noted.

## RECOMMENDED TEST EQUIPMENT

ITEM	SPECIFICATIONS	RECOMMENDED TYPE
Oscilloscope system	Deflection factor 10 mV to 2 V/div. Input impedance 10 Megohms Frequency response dc to 25 MHz	a. Tektronix 7000-series oscilloscope equipped with readout, 7B-series Time-Base, 7A15A Amplifier, and a 1X probe. (7A13 Differential Comparator used in place of 7A15A for calibrated offset voltages.)
Voltmeter (Non-loading digital multimeter)	Input impedance 10 Megohms Range (full scale) 2 V to 20 V	a. Tektronix 7D13 Digital Multimeter (oscilloscope system must have readout). b. Fairchild Model 7050, or equivalent.
Plug-in extender	Capable of extending the 7D12 from the oscilloscope plug-in compartment	a. Tektronix Part No. 067-0589-00 (rigid) or Tektronix Part No. 067-0616-00 (flexible).

## 7D12 AND 067-0700-00 CONTROL SETTINGS

VERTICAL DISPLAY ATTEN	1X
TRIGGERING	AUTO
GATE	OUT-OFF
VERTICAL DISPLAY POSITION	Center trace on graticule
Readout Mode Switch	Out-atten readout check
Internal Display Mode Switch	Chop

## VOLTAGE CONDITIONS

Voltage measurements are taken with no signal applied and the trace centered on the graticule. The voltmeter common is connected to floating ground. The 7D12 is connected to one of the vertical compartments of the oscilloscope mainframe through the plug-in extender. The 7D13, if used, is inserted into the other vertical compartment.

## WAVEFORM CONDITIONS

The 7D12 is connected to one of the vertical compartments of the oscilloscope mainframe through the plug-in extender. The amplifier plug-in, 7A15A or 7A13 is inserted into the other vertical compartment.

The 10X probe ground strap is connected to the floating ground (FGND) test point.

If the 7A15A Amplifier plug-in is used, the input should be ac coupled.

Tolerances of the voltages and waveforms shown are  $\pm 20\%$ .

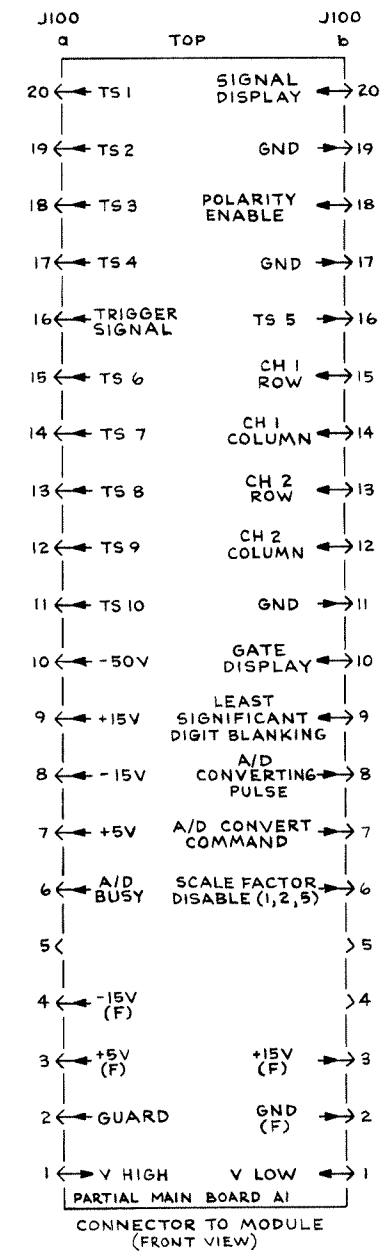
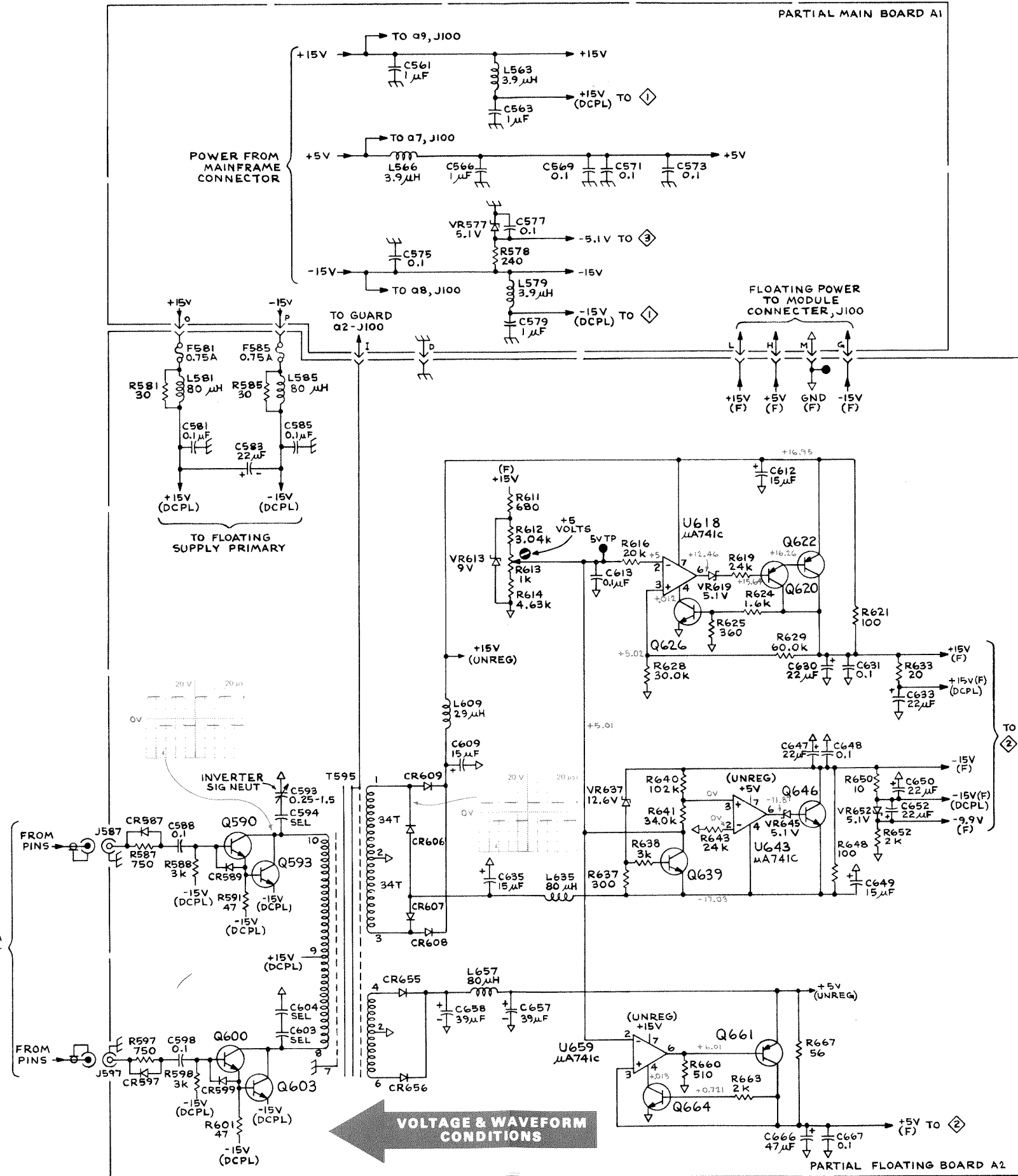
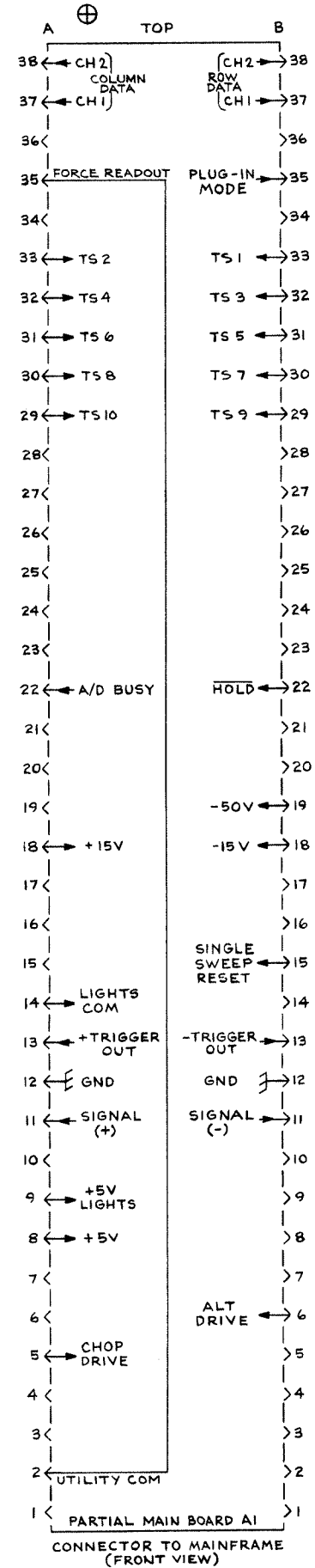

SEE PARTS LIST FOR SEMICONDUCTOR TYPES.

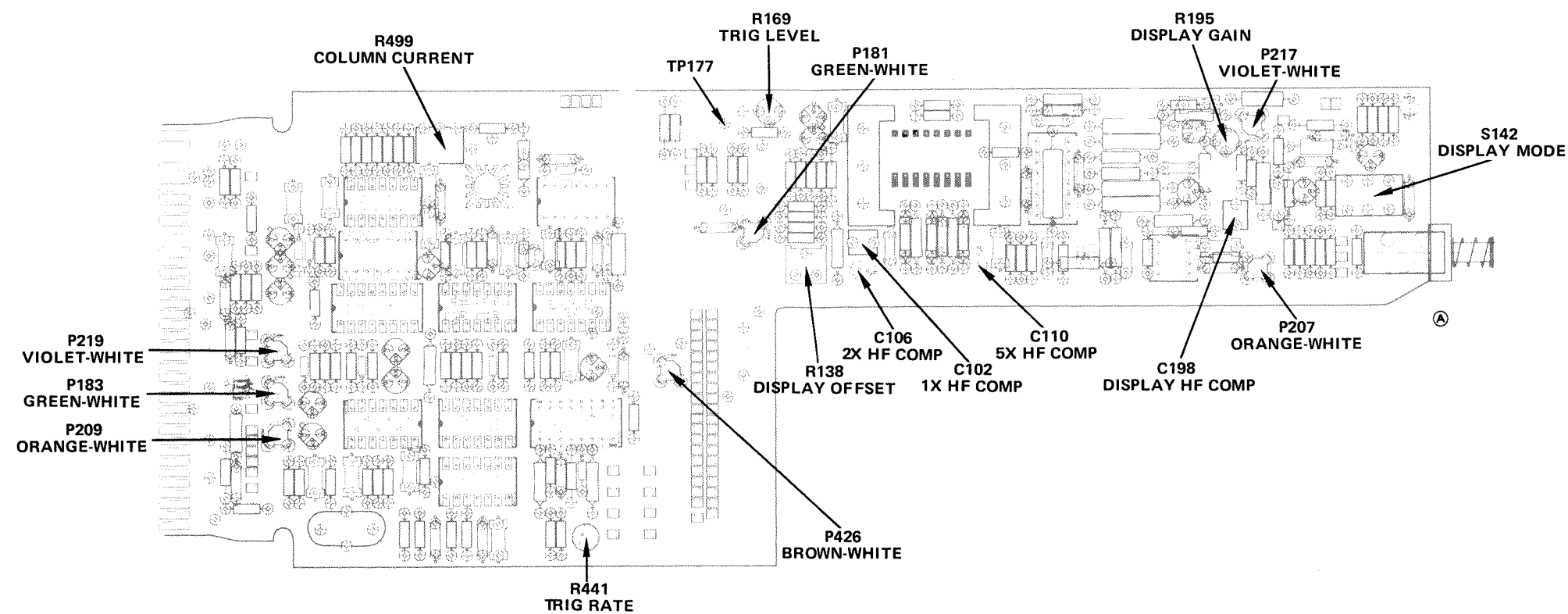

Fig. 6-7. (A1) Main circuit board adjustment locations.

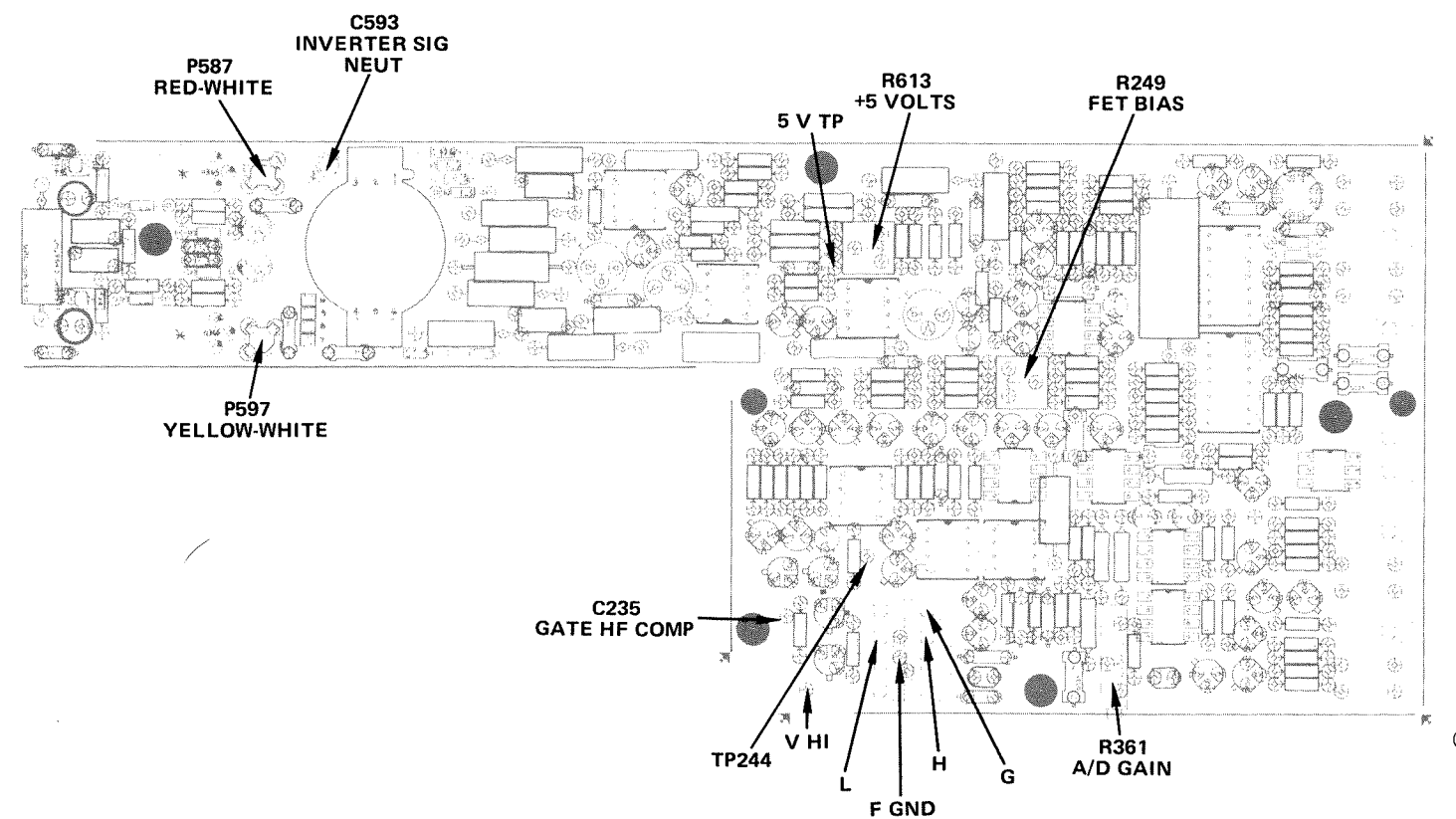

Fig. 6-8. (A2) Floating circuit board adjustment locations.

ADJUSTMENT LOCATIONS

# MECHANICAL REPLACEABLE PARTS LIST

## PARTS ORDERING INFORMATION

Replacement parts are available from or through your local Tektronix, Inc. Field Office or representative.

Changes to Tektronix instruments are sometimes made to accommodate improved components as they become available, and to give you the benefit of the latest circuit improvements developed in our engineering department. It is therefore important, when ordering parts, to include the following information in your order: Part number, instrument type or number, serial number, and modification number if applicable.

If a part you have ordered has been replaced with a new or improved part, your local Tektronix, Inc. Field Office or representative will contact you concerning any change in part number.

Change information, if any, is located at the rear of this manual.

## SPECIAL NOTES AND SYMBOLS

- X000 Part first added at this serial number  
00X Part removed after this serial number

## FIGURE AND INDEX NUMBERS

Items in this section are referenced by figure and index numbers to the illustrations.

## INDENTATION SYSTEM

This mechanical parts list is indented to indicate item relationships. Following is an example of the indentation system used in the description column.

1	2	3	4	5	<i>Name &amp; Description</i>
					<i>Assembly and/or Component</i>
					<i>Attaching parts for Assembly and/or Component</i>
				--- * ---	
					<i>Detail Part of Assembly and/or Component</i>
					<i>Attaching parts for Detail Part</i>
				--- * ---	
					<i>Parts of Detail Part</i>
					<i>Attaching parts for Parts of Detail Part</i>
				--- * ---	

Attaching Parts always appear in the same indentation as the item it mounts, while the detail parts are indented to the right. Indented items are part of, and included with, the next higher indentation. The separation symbol --- \* --- indicates the end of attaching parts.

**Attaching parts must be purchased separately, unless otherwise specified.**

## ITEM NAME

In the Parts List, an Item Name is separated from the description by a colon (:). Because of space limitations, an Item Name may sometimes appear as incomplete. For further Item Name identification, the U.S. Federal Cataloging Handbook H6-1 can be utilized where possible.

## ABBREVIATIONS

"	INCH	FLH	FLAT HEAD	PWR	POWER
#	NUMBER SIZE	FLTR	FILTER	RCPT	RECEPTACLE
ACTR	ACTUATOR	FR	FRAME or FRONT	RES	RESISTOR
ADPTR	ADAPTER	FSTNR	FASTENER	RDG	RIGID
ALIGN	ALIGNMENT	FT	FOOT	RLF	RELIEF
AL	ALUMINUM	FXD	FIXED	RTNR	RETAINER
ASSEM	ASSEMBLED	GSKT	GASKET	SCH	SOCKET HEAD
ASSY	ASSEMBLY	HDL	HANDLE	SCOPE	OSCILLOSCOPE
ATTEN	ATTENUATOR	HEX	HEXAGON	SCR	SCREW
AWG	AMERICAN WIRE GAGE	HEX HD	HEXAGONAL HEAD	SE	SINGLE END
BD	BOARD	HEX SOC	HEXAGONAL SOCKET	SECT	SECTION
BRKT	BRACKET	HLCPS	HELICAL COMPRESSION	SEMICON	SEMICONDUCTOR
BRS	BRASS	HLEXT	HELICAL EXTENSION	SHLD	SHIELD
BRZ	BRONZE	HV	HIGH VOLTAGE	SHLDR	SHOULDERED
BSHG	BUSHING	IC	INTEGRATED CIRCUIT	SKT	SOCKET
CAB	CABINET	ID	INSIDE DIAMETER	SL	SLIDE
CAP	CAPACITOR	IDENT	IDENTIFICATION	SLFLKG	SELF-LOCKING
CER	CERAMIC	IMPLR	IMPELLER	SLVG	SLEEVING
CHAS	CHASSIS	IN	INCH	SPR	SPRING
CKT	CIRCUIT	INCAND	INCANDESCENT	SQ	SQUARE
COMP	COMPOSITION	INSUL	INSULATOR	SST	STAINLESS STEEL
CONN	CONNECTOR	INTL	INTERNAL	STL	STEEL
COV	COVER	LPHLDR	LAMPHOLDER	SW	SWITCH
CPLG	COUPLING	MACH	MACHINE	T	TUBE
CRT	CATHODE RAY TUBE	MECH	MECHANICAL	TERM	TERMINAL
DEG	DEGREE	MTG	MOUNTING	THD	THREAD
DWR	DRAWER	NIP	NIPPLE	THK	THICK
ELECTRN	ELECTRON	NON WIRE	NOT WIRE WOUND	TNSN	TENSION
ELEC	ELECTRICAL	OB	ORDER BY DESCRIPTION	TPG	TAPPING
ELECTLT	ELECTROLYTIC	OD	OUTSIDE DIAMETER	TRH	TRUSS HEAD
ELEM	ELEMENT	OVH	OVAL HEAD	V	VOLTAGE
EPL	ELECTRICAL PARTS LIST	PH BRZ	PHOSPHOR BRONZE	VAR	VARIABLE
EQPT	EQUIPMENT	PL	PLAIN or PLATE	W/	WITH
EXT	EXTERNAL	PLSTC	PLASTIC	WSHR	WASHER
FIL	FILLISTER HEAD	PN	PART NUMBER	XFMR	TRANSFORMER
FLEX	FLEXIBLE	PNH	PAN HEAD	XSTR	TRANSISTOR

## CROSS INDEX MFR. CODE NUMBER TO MANUFACTURER

MFR.CODE	MANUFACTURER	ADDRESS	CITY,STATE,ZIP
0000C	Gettig Engineering and Manufacturing Co.		Springmill, PA 16875
00779	AMP, Inc.	P. O. Box 3608	Harrisburg, PA 17105
05574	Viking Industries, Inc.	21001 Nordhoff	Chatsworth, CA 91311
05820	Wakefield Engineering, Inc.	Audubon Rd.	Wakefield, MA 01880
13257	Esna, Ltd.	10 Esna Park Dr.	Markham, Ontario, Canada
22526	Berg Electronics, Inc.	Youk Expressway	New Cumberland, PA 17070
24931	Specialty Connector Co., Inc.	3560 Madison Ave.	Indianapolis, IN 46227
70276	Allen Mfg. Co.	P. O. Drawer 570	Hartford, CT 06101
71785	TRW Electronic Components, Cinch Connector Operations	1501 Morse Ave.	Elk Grove Village, IL 60007
73743	Fischer Special Mfg. Co.	446 Morgan St.	Cincinnati, OH 45206
73803	Texas Instruments, Inc., Metallurgical Materials Div.		Attleboro, MA 02703
74445	Holo-Krome Co.	31 Brook St. West	Hartford, CT 06110
77250	Pheoll Manufacturing Co., Division of Allied Products Corp.	5700 W. Roosevelt Rd.	Chicago, IL 60650
78189	Illinois Tool Works, Inc. Shakeproof Division	St. Charles Road	Elgin, IL 60126
80009	Tektronix, Inc.	P. O. Box 500	Beaverton, OR 97005
83385	Central Screw Co.	2530 Crescent Dr.	Broadview, IL 60153
87308	N. L. Industries, Inc., Southern Screw Div.	P. O. Box 1360	Statesville, NC 28677
97464	Industrial Retaining Ring Co.	57 Cordier St.	Irvington, NJ 07111

Fig. & Index No.	Tektronix Part No.	Serial/Model No. Eff	Dscnt	Qty	Name & Description					Mfr Code	Mfr Part Number
					1	2	3	4	5		
1-1	337-1064-00			2	SHLD, SIDE, ELEC: PLUG-IN					80009	337-1064-00
-2	366-1023-01			1	KNOB: GRAY W/ SETSCREW					80009	366-1023-01
	213-0153-00			1	. SETSCREW: 5-40 X 0.125 INCH, HEX SOC STL					74445	OBD
-3	366-1408-00			1	KNOB: GRAY WITH SETSCREW					80009	366-1408-00
	213-0153-00			2	. SETSCREW: 5-40 X 0.125 INCH, HEX SOC STL					74445	OBD
-4	366-0392-00			1	KNOB: GRAY					80009	366-0392-00
-5	366-1257-14			1	PUSH BUTTON: GRAY--ON					80009	366-1257-14
-6	366-1058-25			1	KNOB: LATCH, 7D12 (ATTACHING PARTS)					80009	366-1058-25
-7	214-1095-00			1	PIN, SPG, SPLIT: 0.094 OD X 0.187 INCH LONG - - - * - - -					13257	52-022-094-0187
-8	105-0076-00			1	REL BAR, LATCH: PLUG-IN UNIT					80009	105-0076-00
-9	214-1280-00			1	SPRING, HLCPS: 0.14 OD X 1.126"L, 0.16"DIA W					80009	214-1280-00
-10	426-0681-00			1	FR, PUSH BUTTON: GRAY PLASTIC					80009	426-0681-00
-11	333-1634-00			1	PANEL, FRONT: (ATTACHING PARTS)					80009	333-1634-00
-12	210-0457-00			2	NUT, PLAIN, EXT W: 6-32 X 0.312 INCH, STL					83385	OBD
-13	210-0405-00			2	NUT, PLAIN, HEX.: 2-56 X 0.188 INCH, BRS - - - * - - -					73743	2X12157-402
-14	352-0324-00			1	HOLDER, SEMICON:					80009	352-0324-00
-15	131-0955-00			1	CONNECTOR, RCPT.: BNC, FEMALE					24931	28JR200-1
-16	210-0255-00			1	TERMINAL, LUG: 0.391" ID INT TOOTH					80009	210-0255-00
-17	-----			1	CKT BOARD ASSY: TRIG MODE SW (SEE A3 EPL) (ATTACHING PARTS)						
-18	211-0156-00			2	SCREW, MACHINE: 1-72 X 0.25", 82 DEG, FLH STL - - - * - - -					77250	OBD
-19	386-2444-00			1	SUPPORT, CKT BD: (ATTACHING PARTS)					80009	386-2444-00
-20	211-0101-00			1	SCREW, MACHINE: 4-40 X 0.25" 100 DEG, FLH STL					83385	OBD
-21	210-0003-00			1	WASHER, LOCK: EXT #4 - - - * - - -					78189	1104-00-00-0541C
-22	-----			1	RES., VAR: (SEE R120 EPL) (ATTACHING PARTS)						
	213-0020-00			1	SETSCREW: 6-32 X 0.125 INCH, HEX SOC STL - - - * - - -					70276	OBD
-23	348-0235-00			2	SHLD GSKT, ELEC: 4.734 INCH LONG					80009	348-0235-00
-24	386-2444-00			1	SUPPORT, CKT BD: (ATTACHING PARTS)					80009	386-2444-00
-25	213-0192-00			4	SCR, TPG, THD FOR: 6-32 X 0.50 INCH, PNH STL - - - * - - -					87308	OBD
-26	105-0075-00			1	BOLT, LATCH: 0.475 X 0.21 X 0.184", PLSTC					80009	105-0075-00
-27	214-1054-00			1	SPRING, DETENT: LATCH					80009	214-1054-00
-28	351-0347-00			1	GUIDE, MODULE: BOTTOM (ATTACHING PARTS)					80009	351-0347-00
-29	211-0101-00			3	SCREW, MACHINE: 4-40 X 0.25" 100 DEG, FLH STL - - - * - - -					83385	OBD
-30	407-1130-00			1	BRACKET, MODULE: RETAINING (ATTACHING PARTS)					80009	407-1130-00
-31	211-0101-00			1	SCREW, MACHINE: 4-40 X 0.25" 100 DEG, FLH STL - - - * - - -					83385	OBD
-32	-----			1	CKT BOARD ASSY: FLOATING (SEE A2 EPL) (ATTACHING PARTS)						
-33	211-0155-00			4	SCREW, EXT, RLV B: 4-40 X 0.375 INCH, SST - - - * - - -					80009	211-0155-00
-34	131-0566-00			-	. CKT BOARD ASSY INCLUDES:						
-35	131-1003-00			2	. LINK, TERM. CONNE: 0.086 DIA X 2.375 INCH L					0000C	L-2007-1
-36	136-0252-04			2	. CONNECTOR BODY, : CKT BD MT, 3 PRONG					80009	131-1003-00
-37	136-0261-00			4	. CONTACT, ELEC: 0.188 INCH LONG					22526	75060
-38	136-0263-03			4	. CONTACT, ELEC: FOR 0.22 INCH PIN					00779	1-331677-6
-39	136-0183-00			16	. CONTACT, ELEC: FOR 0.025 INCH SQUARE PIN					00779	86250-2
-40	214-0579-00			1	. SOCKET, PLUG-IN: 3 PIN					80009	136-0183-00
-41	214-1292-00			6	. TERM., TEST PT: 0.40 INCH LONG					80009	214-0579-00
-42	214-1611-00			1	. HEAT SINK, ELEC: TRANSISTOR					05820	205-AB
-43	342-0172-00			2	. HEAT SINK, XSTR: TO 5 CUP CLIP, 500VAC					05820	260-4TSE-C4631
				1	. INSULATOR, XFMR: (ATTACHING PARTS)					80009	342-0172-00
-44	211-0008-00			1	. SCREW, MACHINE: 4-40 X 0.25 INCH, PNH STL - - - * - - -					83385	OBD



Mechanical Parts List—7D12

Fig. & Index No.	Tektronix Part No.	Serial/Model No. Eff Dscont	Qty						Name & Description	Mfr Code	Mfr Part Number	
				1	2	3	4	5				
1-45	361-0238-00		4						. SPACER, SLEEVE:0.25 OD X 0.34 INCH LONG	80009	361-0238-00	
-46	337-1684-00		1						SHIELD, ELEC:CKT BD	80009	337-1684-00	
-47	407-1516-00		1						BRACKET, ANGLE:MAIN CKT BD (ATTACHING PARTS)	80009	407-1516-00	
-48	210-0586-00		3						NUT, PLAIN, EXT W:4-40 X 0.25 INCH, STL	78189	OBD	
-49	211-0101-00		2						SCREW, MACHINE:4-40 X 0.25" 100 DEG, FLH STL	83385	OBD	
-50	-----		1						CKT BOARD ASSY:MAIN (SEE A1 EPL) (ATTACHING PARTS)			
-51	211-0116-00		2						SCR, ASSEM WSHR:4-40 X 0.312 INCH, PNH BRS	83385	OBD	
-52	211-0154-00		1						SCR, ASSEM WSHR:4-40 X 0.562 INCH, PNH BRS	83385	OBD	
-53	131-0604-00		-						CKT BOARD ASSY INCLUDES:			
-54	131-0589-00		8						CONTACT, ELEC:0.025 SQ X 0.365 INCH LONG	80009	131-0604-00	
	131-0608-00		3						CONTACT, ELEC:0.46 INCH LONG	22526	47350	
-55	131-0591-00		11						CONTACT, ELEC:0.365 INCH LONG	22526	47357	
-56	131-1003-00		16						CONTACT, ELEC:0.835 INCH LONG	22526	47352	
-57	131-1262-00		7						CONNECTOR BODY:CKT BD MT, 3 PRONG	80009	131-1003-00	
-58	136-0260-01		1						CONNECTOR, RCPT:20/40 CONTACT, RIGHT ANGLE	05574	3VH20/1JKC15	
-59	136-0269-02		2						SOCKET, PLUG-IN:16 CONTACT, RECT SHAPE	71785	133-51-02-075	
-60	136-0252-04		8						SOCKET, PLUG-IN:14 CONTACT, RECT SHAPE	73803	IC-014ST-7559	
-61	136-0234-00		89						CONTACT, ELEC:0.188 INCH LONG	22526	75060	
-62	352-0096-00		2						CONTACT, ELEC:0.088 OD X 0.247 INCH L	00779	380598-1	
-63	-----		1						CLIP, SPR, TNSN:CRYSTAL	80009	352-0096-00	
			1						RES., VAR: (SEE R131 EPL) (ATTACHING PARTS)			
-64	210-0046-00		1						WASHER, LOCK:INTL, 0.26 ID X 0.40" OD, STL	78189	1214-05-00-0541C	
-65	210-0583-00		1						NUT, PLAIN, HEX.:0.25-32 X 0.312 INCH, BRS	73743	2X20319-402	
-66	214-0579-00		1						TERM., TEST PT:0.40 INCH LONG	80009	214-0579-00	
-67	260-0723-00		1						SWITCH, SLIDE:DPDT, 0.5A, 125VAC	80009	260-0723-00	
-68	260-1132-00		1						SWITCH, PUSH:1 BUTTON, DOUBLE POLE	80009	260-1132-00	
-69	351-0225-00		4						GUIDE, CKT CARD:	80009	351-0225-00	
-70	355-0518-02		1						STUD, SELF LOCK:4-40 X 0.625 INCH L, BRS	80009	355-0518-02	
-71	376-0051-01		1						CPLG, SHAFT, FLEX:FOR 0.125 INCH, W/SETSCREW	80009	376-0051-01	
	213-0075-00		4						SETSCREW:4-40 X 0.094 INCH, HEX SOC STL	70276	OBD	
-72	384-1127-00		1						EXTENSION SHAFT:7.5 INCH L X 0.125 INCH OD	80009	384-1127-00	
-73	407-0803-00		1						BRKT, COMPONENT:	80009	407-0803-00	
			1						ACTR ASSY, CAM S:ATTEN (SEE S110 EPL) (ATTACHING PARTS)			
-74	211-0116-00		4						SCR, ASSEM WSHR:4-40 X 0.312 INCH, PNH BRS	83385	OBD	
-75	200-1428-00		1						ACTUATOR ASSY INCLUDES: COVER, CAM SW: (ATTACHING PARTS)	80009	200-1428-00	
-76	211-0008-00		4						SCREW, MACHINE:4-40 X 0.25 INCH, PNH STL	83385	OBD	
-77	210-0004-00		4						WASHER, LOCK:INTL, 0.12 ID X 0.26"OD, STL	78189	1204-00-00-0541C	
-78	210-0406-00		2						NUT, PLAIN, HEX.:4-40 X 0.188 INCH, BRS	73743	2X12161-402	
-79	131-0963-00		2						CONTACT, ELEC:GROUNDING	80009	131-0963-00	
-80	214-1139-02		2						SPRING, FLAT:GREEN COLORED	80009	214-1139-02	
-81	214-1127-00		2						ROLLER, DETENT:0.125 DIA X 0.125 INCH L	80009	214-1127-00	
-82	401-0081-02		1						BEARING, CAM SW:FRONT (ATTACHING PARTS)	80009	401-0081-02	
-83	354-0391-00		1						RING, RETAINING:0.395"FREE ID X 0.025"STL	97464	3100-43-CD	
-84	105-0370-00		1						DRUM, CAM SWITCH:	80009	105-0370-00	
-85	210-0406-00		4						NUT, PLAIN, HEX.:4-40 X 0.188 INCH, BRS	73743	2X12161-402	
-86	401-0115-00		1						BEARING, CAM SW:CENTER	80009	401-0115-00	

Fig. & Index No.	Tektronix Part No.	Serial/Model No.		Qty	1	2	3	4	5	Name & Description	Mfr Code	Mfr Part Number	
		Eff	Dscont										
1-87	386-1402-00			1						PANEL, REAR: (ATTACHING PARTS)	80009	386-1402-00	
-88	213-0192-00			4						SCR, TPG, THD FOR: 6-32 X 0.50 INCH, PNH STL	87308	OBD	
-89	361-0326-00			1						SPACER, SLEEVE: 0.18 ID X 0.25 OD X 0.10"L - - - * - - -	80009	361-0326-00	
-90	220-0547-00			2						NUT, BLOCK: 0.38 X 0.25 X 0.282 INCH OA (ATTACHING PARTS FOR EACH)	80009	220-0547-00	
-91	211-0105-00			1						SCREW, MACHINE: 4-40 X 0.188"100 DEG, FLH STL - - - * - - -	83385	OBD	
-92	214-1061-00			1						SPRING, GROUND: FLAT	80009	214-1061-00	
-93	426-0505-19			1						FR SECT, PLUG-IN: TOP	80009	426-0505-19	
-94	220-0547-00			1						NUT, BLOCK: 0.38 X 0.25 X 0.282 INCH OA (ATTACHING PARTS)	80009	220-0547-00	
-95	211-0105-00			1						SCREW, MACHINE: 4-40 X 0.188"100 DEG, FLH STL - - - * - - -	83385	OBD	
-96	426-0499-15			1						FR SECT, PLUG-IN: BOTTOM	80009	426-0499-15	
-97	179-1882-00			1						WIRING HARNESS: - . WIRING HARNESS INCLUDES:			
-98	131-0707-00			8						. CONTACT, ELEC: 0.48"L, 22-26 AWG WIRE	22526	47439	
-99	352-0162-00			1						. HOLDER, TERM.CON: 4 WIRE BLACK	80009	352-0162-00	
-100	352-0163-00			1						. HOLDER, TERM.CON: 5 WIRE BLACK	80009	352-0163-00	
-101	210-0774-00			9						. EYELET, METALLIC: 0.152 OD X 0.245 INCH L, BRS	80009	210-0774-00	
-102	210-0775-00			9						. EYELET, METALLIC: 0.126 OD X 0.23 INCH L, BRS	80009	210-0775-00	
-103	131-0707-00			3						CONTACT, ELEC: 0.48"L, 22-26 AWG WIRE	22526	47439	
-104	352-0199-00			1						HOLDER, TERM.CON: 3 WIRE BLACK	80009	352-0199-00	
-105	214-1140-00			4						SPRING, HLCPS: 0.251 OD X 0.375 INCH LONG	80009	214-1140-00	



FIG. 1 EXPLODED VIEW

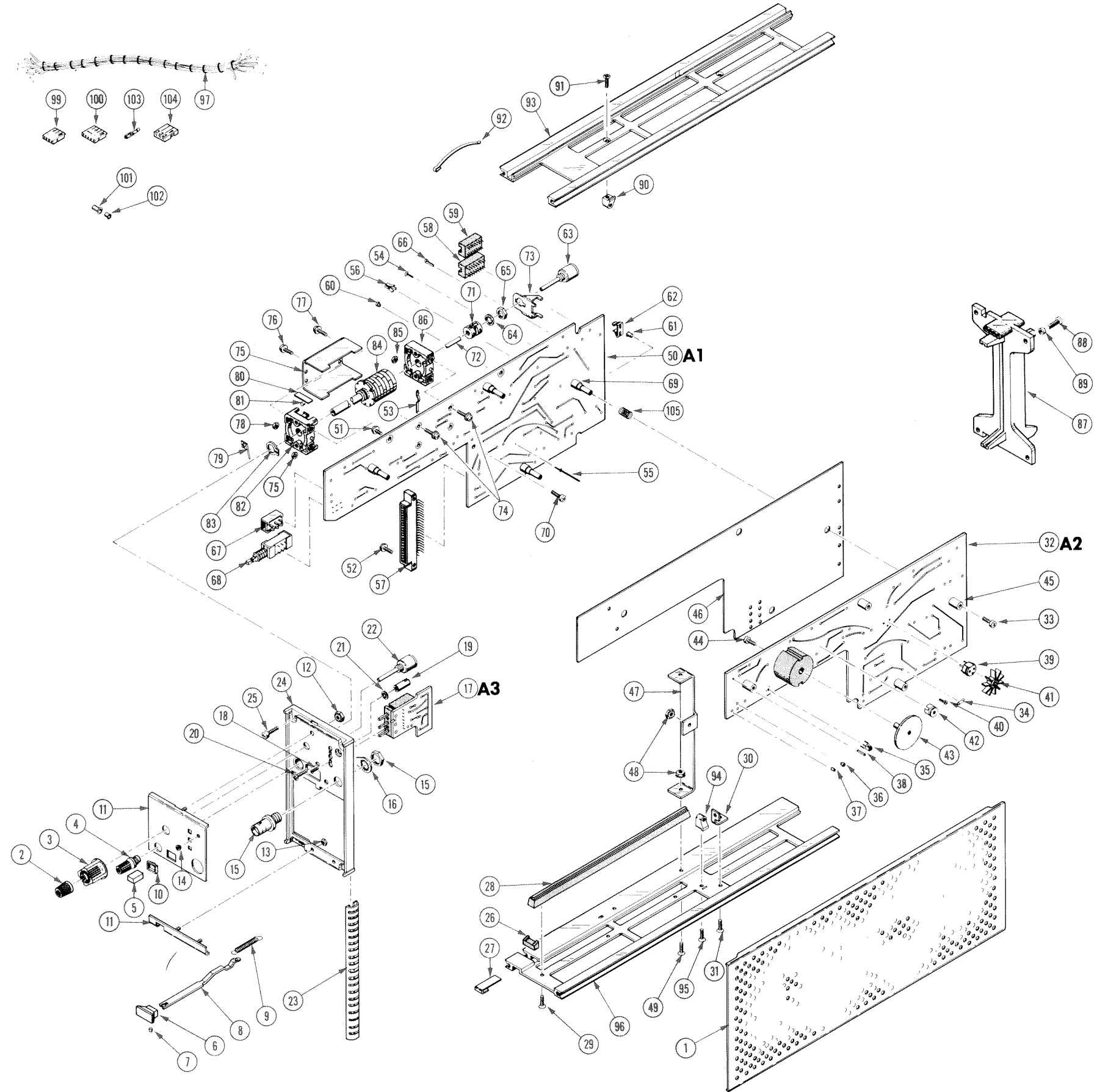

7D12 A/D CONVERTER



+

**ACCESSORIES**

Fig. & Index No.	Tektronix Part No.	Serial/Model No.		Qty	1	2	3	4	5	Name & Description	Mfr	
		Eff	Dscont								Code	Mfr Part Number
2 -	070-1470-00			1						MANUAL, TECH: INSTRUCTION (NOT SHOWN)	80009	070-1470-00

**REPACKAGING**

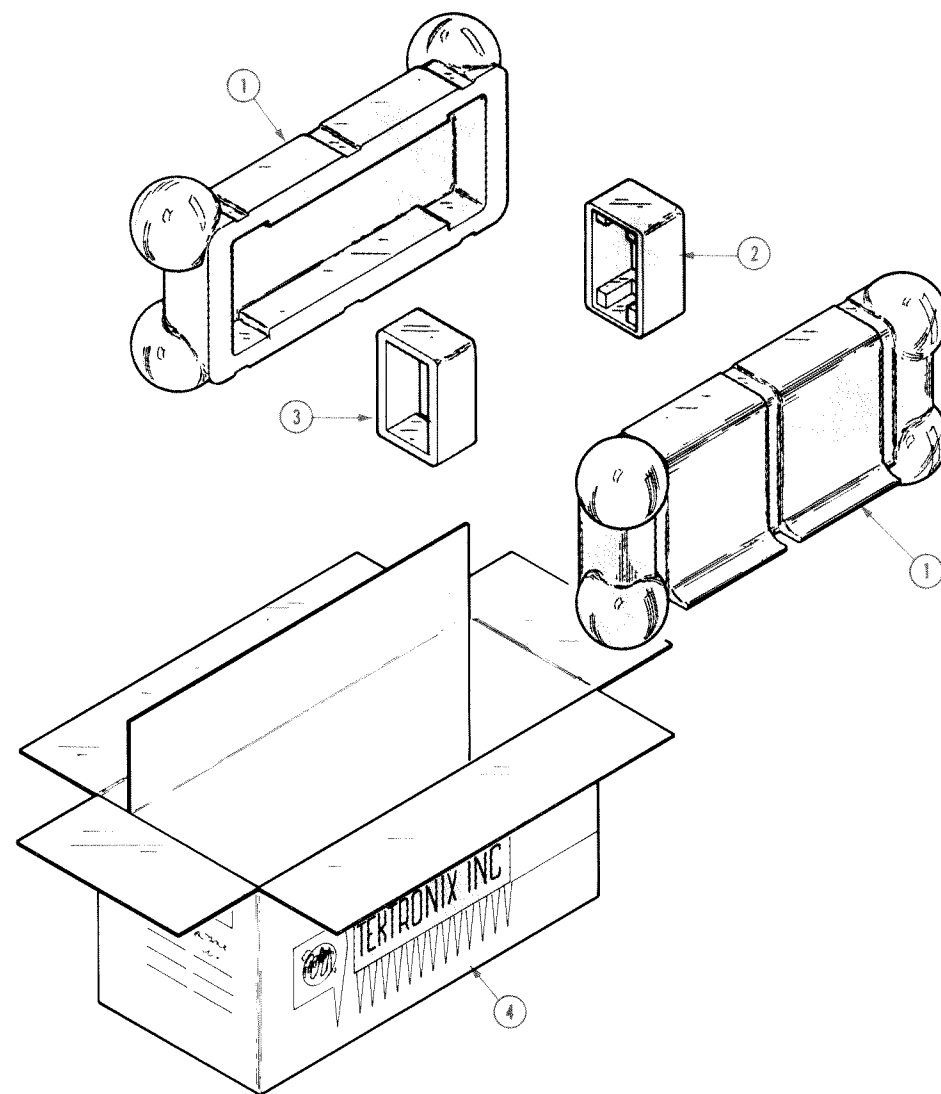
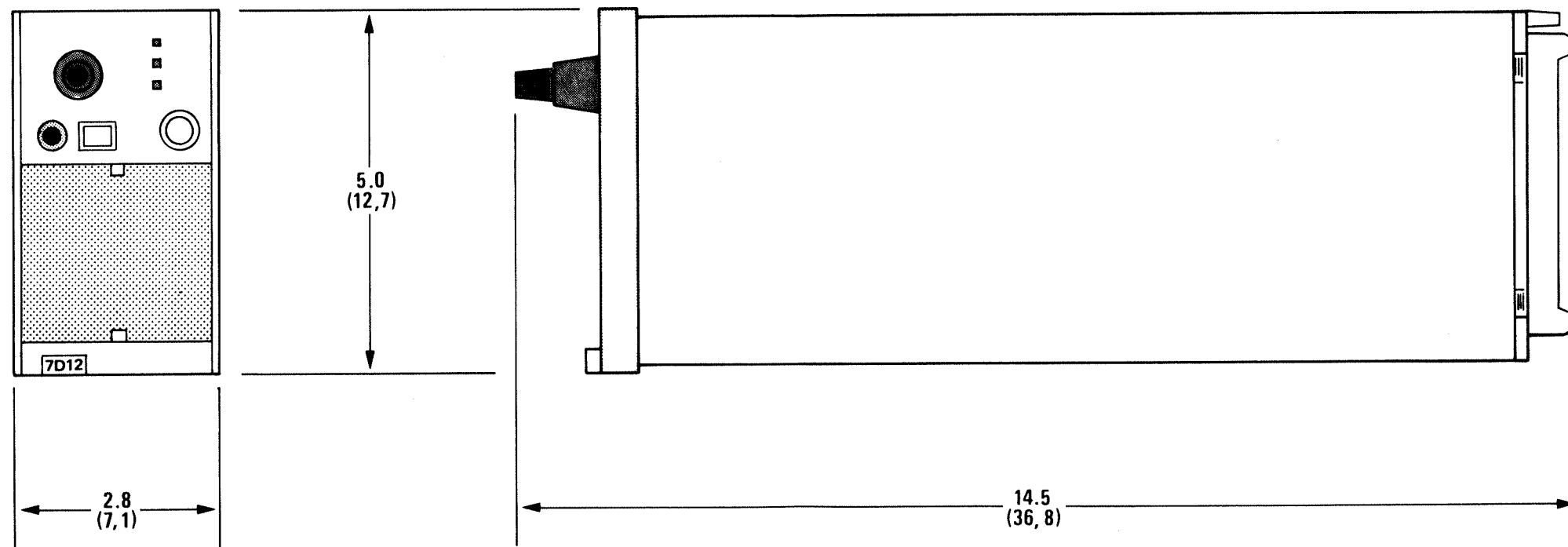

Fig. & Index No.	Tektronix Part No.	Serial/Model No.		Qty	1	2	3	4	5	Name & Description	Mfr	
		Eff	Dscont								Code	Mfr Part Number
3-	065-0125-00			1						CARTON ASSY:	80009	065-0125-00
-1	004-0241-00			2						. CASE HALF:	80009	004-0241-00
-2	004-0242-00			1						. END CAP: REAR	80009	004-0242-00
-3	004-0243-00			1						. END CAP: FRONT	80009	004-0243-00
-4	004-0748-00			1						. CARTON:	80009	004-0748-00

+

OVERALL DIMENSIONS  
(MEASURED AT MAXIMUM POINTS)



Note: Top figures are in inches and  
lower figures in centimeters.

Weight:  $\approx$  2.2 lbs. ( $\approx$  .992 kg.)

FIG. 4 DIMENSIONS

## **MANUAL CHANGE INFORMATION**

At Tektronix, we continually strive to keep up with latest electronic developments by adding circuit and component improvements to our instruments as soon as they are developed and tested.

Sometimes, due to printing and shipping requirements, we can't get these changes immediately into printed manuals. Hence, your manual may contain new change information on following pages.

A single change may affect several sections. Sections of the manual are often printed at different times, so some of the information on the change pages may already be in your manual. Since the change information sheets are carried in the manual until ALL changes are permanently entered, some duplication may occur. If no such change pages appear in this section, your manual is correct as printed.







**TEKTRONIX®**

*committed to  
technical excellence*

# MANUAL CHANGE INFORMATION

PRODUCT 7D12 Service

CHANGE REFERENCE M23,033

EFF SN B060000-up

DATE 10-28-74

CHANGE:

DESCRIPTION

## ELECTRICAL PARTS LIST AND SCHEMATIC CHANGES

CHANGE TO:

L609      108-0200-00      COIL,RF:52 $\mu$ H

T595      120-0849-01      XFMR,POWER:POT CORE

L609 and T595 are located on diagram  POWER & CONNECTORS.





**TEKTRONIX**<sup>®</sup>  
committed to  
technical excellence

# MANUAL CHANGE INFORMATION

PRODUCT 7D12  
EFF SN B070000-up

CHANGE REFERENCE M23,892  
DATE 9-25-75

CHANGE:

DESCRIPTION

070-1470-00

ELECTRICAL PARTS LIST AND SCHEMATIC CHANGE

ADD:

R549      315-0101-00      RES., FXD, COMP:100 OHM,5%,0.25W

DIAGRAM 3 LOGIC - Partial

